

HARMONICS AND TECHNICAL BARRIERS IN ADJUSTABLE SPEED DRIVES

Copyright Material IEEE
Paper No. PCIC-88-14

Robert A. Hanna, Senior Member, IEEE
Petro-Canada Products Inc.
Oakville, Ontario, Canada

ABSTRACT

All Thyristor adjustable speed drives, unlike fixed speed, generate harmonics to some degree. Harmonics are currents and voltages that are multiples of the fundamental 60 Hz frequency. Any power converter, which converts AC to DC or DC to AC, can be considered to be a source of harmonics. This paper reviews the characteristics of harmonics produced by an adjustable speed drive system, methods of reducing them, and presents installation examples.

INTRODUCTION

From the standpoint of the main power system harmonics, only the AC to DC power converter is a factor. The DC link isolates the motor converter and motor from the power system. The Thyristor rectifier chops the AC current waveform by allowing current to flow during a portion of the cycle. These harmonics may produce harmful effects on equipment connected to the plant or electric utility system or neighbouring industrial plant. On the other hand, the motor converter also produces harmonics which can cause motor overheating. This paper analyzes the presence of harmonics in both 6-pulse and 12-pulse converter systems, and highlights the differences between 3-phase and 6-phase machines in suppressing these harmonics. The effect of the use of harmonic filters and special transformer winding arrangement in reducing harmonics is also discussed. Harmonics measurements for two actual installation are presented and analyzed.

SOURCE OF HARMONICS

The common sources of harmonics in utility or industrial electrical systems are the following:

- Rectifiers
- DC motor drives
- Variable frequency AC drives
- Uninterruptible power supplies (UPS)
- Arc furnace
- Static VAR generator
- Cyclo converter
- Static Motor Starters

The presence of these harmonic producing devices in a system does not necessarily constitute a problem. The harmonics may be of sufficiently low magnitude and therefore harmless at one extreme, or they may be of such magnitude to cause damage to equipment in the system. If in existing system there is no history of harmonic related problems such as motor failures, capacitor fuse blowing, capacitor failures, telephone

interference, etc., then there is likely no harmonic problem and a harmonic analysis study is probably not warranted. However, a good guideline is that if 20% or more of the plant load consists of harmonic producing sources, a harmonic study should be considered. This will determine the magnitude of harmonic currents and voltages, and will aid in designing special filters to reduce these distortions.

HARMONICS

A harmonic is defined as a sinusoidal component of a periodic wave having a frequency that is an integral multiple of the fundamental frequency. For example, a component, the frequency of which is five times the fundamental frequency, is called a fifth harmonic. The theoretical maximum amplitude of each harmonic current produced by a converter is equal to that of the fundamental component divided by harmonic order. For example, the 5th harmonic is equal to 20% of the load current; and the 7th harmonic is equal to 14.3%; and so on. These values are for an idealized square wave and, in practice, will be less because of system impedance. The harmonic components are shown in Fig. 1 and each harmonic is assumed to be in phase with the fundamental. Fig. 2 shows how the addition of 3rd, 5th and 7th harmonics, also in phase, results in a flat top waveform. The resulting wave shape will depend on the magnitude and the phase relation of each of the harmonic components.

A static power converter generates harmonic currents the order of which is given by the equation:

$$n = kp \pm 1$$

where,

- n = order of the harmonic
- k = is an integer 1, 2, 3
- p = number of pulses of the converter system

A 6-pulse converter, as shown in Fig. 3 would generate harmonic currents of the order, 5th, 7th, 11th, 13th, 17th, 19th, 23rd, 25th, etc. For a 12-pulse converter configuration, as shown in the Fig. 4, the harmonic generated are 11th, 13th, 23rd, 25th, etc. Therefore, a 12-pulse converter system provides a significant reduction in the voltage distortion and, equally important, it eliminates (assuming balanced conditions) the lowest order harmonics of 5th and 7th which are typically of most concern.

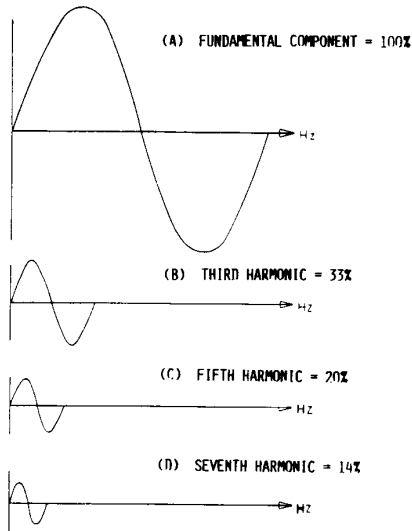

FIG. 1. COMPONENTS OF SQUARE WAVE: FUNDAMENTAL AND HARMONIC COMPONENTS EACH OF A MAGNITUDE INVERSE TO ITS ORDER.

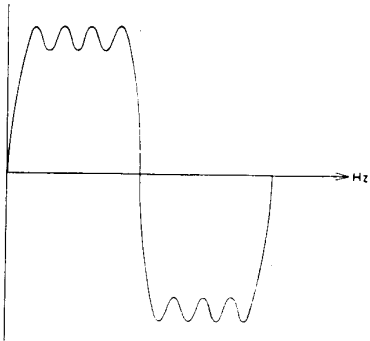

FIG. 2. WAVEFORM RESULTING FROM ADDING FUNDAMENTAL + 3RD + 5TH + 7TH HARMONIC COMPONENTS ALL BEING IN PHASE AND EACH HARMONIC OF A MAGNITUDE INVERSE TO ITS ORDER.

In order to compare levels of harmonic distortion in a power system, the harmonic distortion factor (HDF) is used, and is defined in IEEE Standard 519-1981 as:

$$HDF = \left(\frac{\text{sum of squares of amplitudes of all harmonics}}{\text{square of amplitude of fundamental}} \right)^{\frac{1}{2}} \cdot 100\%$$

Harmonic distortion standards are needed to:

1. Ensure users are provided with a suitable voltage supply waveform.
2. Limit distortions to levels that system components can tolerate.
3. Prevent the power system from interfering with the operation of other systems.

The IEEE Standard 519-1981 specifies guidelines with regard to limiting the harmonic voltage distortion factor. A summary of these guidelines is given in Table 1.

The amount of voltage distortion that can be tolerated on a power system is dependent upon the equipment connected to it and this equipment's susceptibility to nonsinusoidal wave shapes. If voltage distortion is kept within the limits given in Table 1, other equipment will operate satisfactorily. Power utility companies may be more stringent or relaxed in their specifications for the harmonic distortion factor, and may use different formulas than those given in IEEE Standards. In Canada, for example, the requirements for harmonic distortion factors vary from utility to utility, but in general they range from 1% to 5% depending on the system voltage level. The higher the voltage level the more stringent become the harmonic limitation requirements. It is therefore necessary to check with the power company as to their requirements in limiting harmonic voltages and currents as this may have substantial impact on the drive and filter design.

EFFECT OF HARMONICS ON ELECTRICAL MACHINES

In examining the effects of harmonics on power system components, one can make a major division between static non-rotating devices (such as transformers, cable and capacitors) and motors. The concern over harmonics in static devices is of a single dimension, i.e. increased heating. This also is of concern in motors, but is a more complicated evaluation because of the different manner in which the harmonics are impressed on the stator and rotor, and the significant differences in the physical design and thermal response to harmonic heating of the stator and rotor.

The other dimension involved in the analysis of rotating machines is the potential exists for harmonics to excite complex vibration mode involving structural resonances in the rotor elements of connected equipment, such

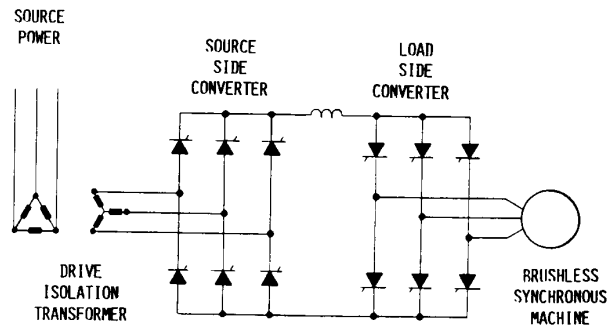

FIG. 3. BASIC CIRCUIT FOR THE SYNCHRONOUS MACHINE ADJUSTABLE SPEED DRIVE SYSTEM. 6-PULSE CONNECTED TO 3-PHASE MACHINE.

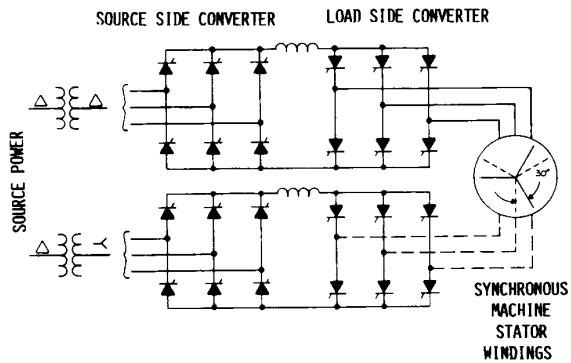

FIG. 4. BASIC CIRCUIT FOR THE SYNCHRONOUS MACHINE ADJUSTABLE SPEED DRIVE SYSTEM. 12-PULSE CONNECTED TO 6-PHASE MACHINE.

TABLE 1

HARMONIC VOLTAGE DISTORTION LIMITS

Power System Voltage Level	Dedicated System Converter	General Power Systems
460 V	10%	5%
2.4 - 69 KV	8%	5%
115 KV & above	1.5%	1.5%

- Notes: 1. These values are taken from IEEE 519-1981 Standard.
 2. A dedicated system is one serving only converters or loads not affected by voltage distortion.

as the blades of a compressor. This complexity and the large variety in types and designs of electric motors means there are no precise application guidelines available for rotor elements of connected equipment, such as the blades of a compressor. This complexity and the large variety in types and designs of electric motors means there are no precise application guidelines available for machines operating in nonsinusoidal waveform environments. One should be aware, however, of the general effects that harmonics will have on electric motors.

When a nonsinusoidal voltage generated by a converter is impressed on the stator winding, the result is a circulating harmonic current. The magnitude of harmonic current depends on the stator winding configuration, i.e. 3-phase or 6-phase, harmonic reactances, and rotor damping effect. Each harmonic voltage of the 5th, 7th, 11th, etc., will induce a corresponding harmonic current in the stator winding. Note that each of these harmonic orders can be defined as positive or negative sequence in accordance with symmetrical component theory. These harmonic currents will generate additional heating in the stator winding which will add to the temperature rise caused by the fundamental flow of current. Of even greater concern, is the flow of harmonic currents in the rotor. The flow of each harmonic in the stator will produce a series of space harmonic m.m.f.'s (magnetomotive force) in the air gap

which will induce current flow in the rotor. Just as each harmonic current can be defined as being positive or negative sequence, the rotation of space harmonic m.m.f.'s will be either forward or backward with respect to the rotor rotation.

The space harmonics of the stator m.m.f. available in the air gap are determined by the following equation:

$$h = 2 km \pm 1$$

where,

- h = order of space harmonic
- m = number of stator winding phases, 3 or 6
- k = any integer

Tables 2 and 3 show the space harmonics produced in 3-phase and 6-phase winding arrangements, respectively. It can be seen that the 6-phase winding arrangement suppresses more space harmonics than in the 3-phase. The resultant rotor heating and pulsating output torques in 6-phase machines will therefore be less than in 3-phase. In the event, when a 6-phase machine is connected to 12-pulse converter, the level of harmonic currents in the stator and rotor will be greatly reduced.

In the case of a synchronous motor, the frequency of induced harmonic currents in the rotor is determined by the relationship:

$$f_{r_h} = (n \pm h) f_1$$

TABLE 2

Speed and directions of rotation of components of stator m.m.f. of 3-phase winding. Synchronous speed is obtained when $n = 1$, $h = 1$.

Order of Space Harmonic h	Order of Time Harmonic, n					
	1	3	5	7	11	13
1	+1		-5	+7	-11	+13
3		± 1				
5	-1/5		+1	-7/5	$+\frac{11}{5}$	$-\frac{13}{5}$
7	$+\frac{1}{7}$		$-\frac{5}{7}$	+1	$-\frac{11}{7}$	$+\frac{13}{7}$
9		$\pm \frac{1}{3}$				
11	$-\frac{1}{11}$		$+\frac{5}{11}$	$-\frac{7}{11}$	+1	$-\frac{13}{11}$
13	$+\frac{1}{13}$		$-\frac{5}{13}$	$+\frac{7}{13}$	$-\frac{11}{13}$	+1

Any space harmonic of order $h = n$ is stationary with respect to the rotor and interacts with any rotor harmonic of the same order to produce synchronous torque in a similar manner to the interaction of the fundamental components of stator and rotor magnetomotive forces.

TABLE 3

Speed and directions of rotation of components of stator m.m.f. of 6-phase winding. Synchronous speed is when $n = 1$, $h = 1$.

Order of Space Harmonic h	Order of Time Harmonic, n				
	1	5	7	11	13
1	+1			$-\frac{11}{1}$	$+\frac{13}{1}$
3					
5		+1	$-\frac{7}{5}$		
7		$-\frac{5}{7}$	+1		
9					
11	$-\frac{1}{11}$			+1	$-\frac{13}{11}$
13	$-\frac{1}{13}$			$-\frac{11}{13}$	+1

INSTALLATION EXAMPLES

In order to better understand the presence of harmonics in an adjustable speed drive, harmonics measurement for two installation are presented and analyzed. The first installation covers the 6-pulse system and the second a 12-pulse system. The effect of harmonic filters and isolating transformer winding arrangement in reducing harmonics is also reviewed.

CASE 1

Fig. 5 shows a simplified single line diagram for the first drive installation. It consists of the following:

1. Line filters connected to 4.16 KV incoming power supply. Individual 5th, 7th, 11th and 13th harmonic filters are used.
2. 3-phase, 3000 KVA, isolating transformer with delta primary and star secondary.
3. 6-pulse line converter system (rectifier).
4. Reactor.
5. 6-pulse load converter system (inverter).
6. 3-phase brushless synchronous motor rated at 3000 HP, 1000 V, 1800 rpm, 4 poles.

Figs. 6 and 7 show the motor current waveform and harmonic components. It can be seen that the waveform is distorted and the major harmonic components are the 5th, 7th, 11th and 13th. These harmonics must be carefully considered when designing the motor in order to keep the temperature rise in the stator and rotor within the design limits. In this installation, the harmonics were not properly accounted for and the result was temperature rise in the rotor exceeding the design limits. The problem was only discovered during commissioning stage when conducting heat run test. The rotor was of solid pole type and designed for an 80°C temperature rise. The measured rotor temperature rise was satisfactory when connected to 60 Hz supply, but it was in excess of 150°C when energized from load commutated inverter. After considerable discussions with

the motor manufacturer, it was decided to build a new rotor of laminated type to replace the original solid pole rotor in order to correct the overheating problem. In addition, several design modifications were incorporated for the new rotor to further reduce harmonic losses problem, and these were:

1. Add damper bars in the pole face.
2. Decrease the air gap from 0.5 inch to 0.35 inch.
3. Increase the effective exterior surface area of the field winding to achieve better heat dissipation.
4. Use class F insulation for the field winding and for rotor laminations.
5. Improve airflow circulation by replacing the cooling fans.

The rebuilt motor with the laminated rotor underwent heat run test. The measured rotor temperature rise when connected to load commutated inverter was 72°C, and when connected to 60 Hz supply was 48°C. The isolating transformer temperature rise was also measured and found to be above the design value of 115°C. This problem was corrected by providing adequate ventilation. Harmonic currents fed back to the 4.16 KV supply were kept within acceptable level by using individual harmonic filters for 5th, 7th, 11th, 13th and 24th as shown in Fig. 5.

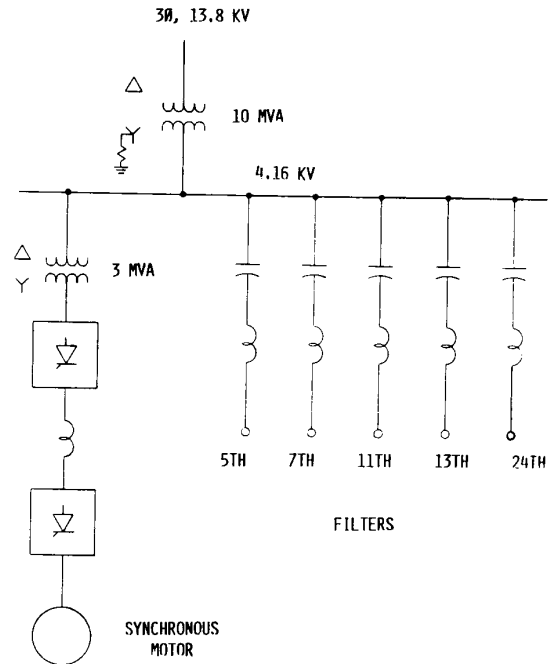

FIG. 5. SIMPLIFIED SINGLE LINE DIAGRAM FOR 2.3 MW ADJUSTABLE SPEED DRIVE HAVING 6-PULSE SYSTEM CONNECTED TO 3-PHASE BRUSHLESS SYNCHRONOUS MOTOR.

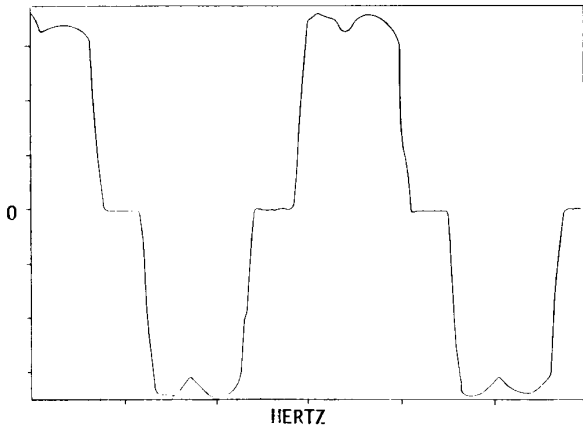

FIG. 6. CURRENT WAVEFORM FOR 3-PHASE SYNCHRONOUS MOTOR RATED AT 2.3 MW, 1000 V, 1800 RPM

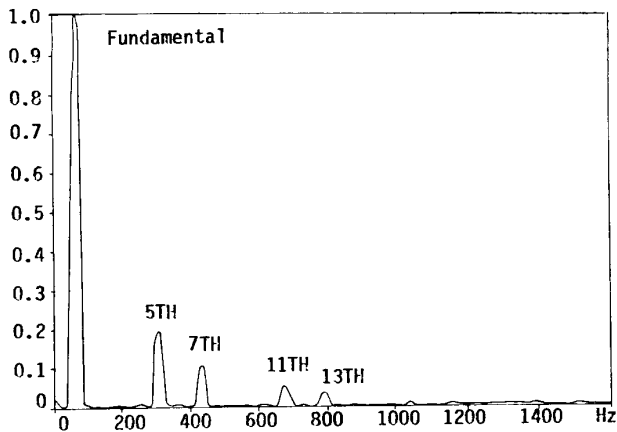

FIG. 7. HARMONIC COMPONENTS FOR CURRENT WAVEFORM IN FIGURE 6.

CASE 2

Fig. 8 shows a simplified single line diagram for the second drive installation. It comprises of the following:

1. Line filters connected to 25KV incoming power lines. These filters provide a sink for the harmonics and are used for power factor correction. The amount of compensation is such that the power factor is always between 0.95 and 1.0 depending on the load. The filter combination used is the high pass type consisting of an inductance in parallel with a resistance and a series capacitance. There are three filter branches, one for the 5th and 7th harmonics, one for the 11th and 13th, and the last one for 23th and higher order harmonics. The reactive power requirements of the drive are met by branch one or two, each providing 3.5 MVAR and the last one providing 2MVAR.

2. 3-phase/6-phase converter transformer rated at 21MVA, 25/2 x 7.3 KV. The primary winding is connected in delta and the secondary consists of two 3-phase winding, one being connected in star and the other in delta. The line voltage is the same for both secondary windings but with a phase shift of 30°. To each secondary winding an independent six pulse rectifier/inverter system is connected and only the winding combination makes it a 12 pulse system. The reason for the use of the 12 pulse system lies in the reduction of harmonics created by the converter. The transformer was specifically designed for this application as the presence of harmonic currents in the secondaries would require considerable oversizing of regular power transformer.
3. 12-pulse line converter system (rectifier).
4. DC-link smoothing reactor.
5. 12-pulse load converter system (inverter). The converters are cooled by deionized water flowing through the thyristor heat sink. Each branch in the converter consists of 6 thyristors in series with the sixth one being redundant for additional protection. Each converter is therefore made of 36 thyristors.

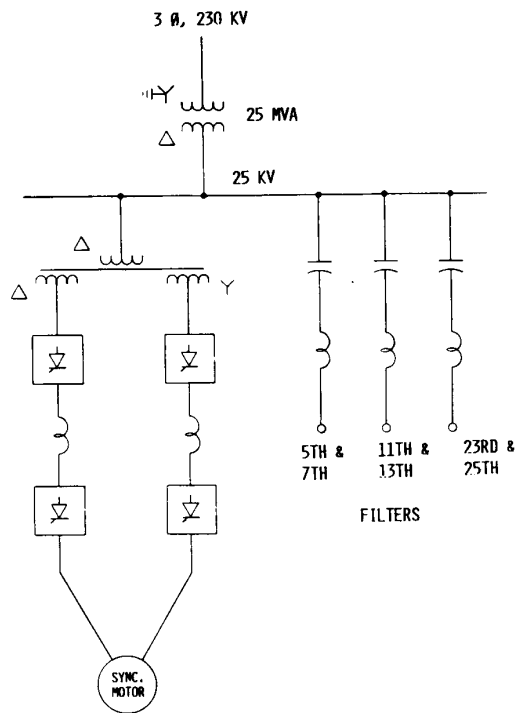

FIG. 8. SIMPLIFIED SINGLE LINE DIAGRAM FOR 17 MW ADJUSTABLE SPEED DRIVE HAVING 12-PULSE SYSTEM CONNECTED TO 6-PHASE BRUSHLESS SYNCHRONOUS MOTOR.

6. 6-phase brushless synchronous machine rated at 17 MW, 7200 V, 6060 rpm, 101 Hz, 2-poles. The rotor is of the cylindrical solid steel type. Non magnetic wedges were used in the rotor to hold the main field windings in place. Because of the reduced penetration of the current into the steel of the rotor, most harmonic currents will flow in the wedge. Therefore, the wedges were also used in the part of the rotor without a field winding. The choice of motor voltage of 7200 V mainly depends on the thyristor converters configuration and the manufacturer design preference. The motor voltage can accordingly be adjusted through selection of the number of winding slots and the number of conductor per slot.

Figs. 9 and 10 show the motor applied voltage and motor input current. It can be seen that both waveforms contain harmonics, the principle ones being the 5th, 7th, 11th and 13th. Under symmetrical and balanced loading conditions, the 5th and 7th harmonic current should be zero in a 12-pulse system but, in reality, they are present.

The effect of the generated harmonic voltages on 6-phase machines is less when compared to 3-phase because of cancellation of certain space harmonics, see Table 3.

Fig. 11 shows the current waveform in the converter transformer secondary side for 12-pulse system. The 5th harmonic current is 10% of fundamental current and the 7th is 4%. Theoretically, a 12-pulse converter does not produce 5th, 7th, 17th and 19th harmonics; but due to unbalances, some will be present. These unbalances might be caused by:

1. Variations in voltage or impedance line - line in three-phase systems (possibly $\pm 2.5\%$).
2. Differences in transformer winding ratios for star and delta winding connections.
3. Differences in thyristor firing pulse angles between multipulse circuits.
4. Variations in thyristor turn-off times.

The 5th and 7th harmonic currents reflected on the primary side can be further reduced or even cancelled when a special transformer arrangement is used. This harmonic reduction is obtained when the primary side is connected in delta and the secondary side consists of two 3-phase winding, one connected in delta and the other in star, with 30° phase shift. The 11th and 13th harmonic currents are not effected by the transformer winding configuration except for the leakage reactance.

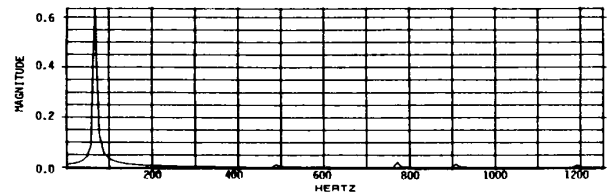

FIG. 9. VOLTAGE WAVEFORM AND ITS HARMONIC SPECTRUM FOR 6-PHASE SYNCHRONOUS MOTOR RATED AT 17 MW, 7200 V, 6000 RPM

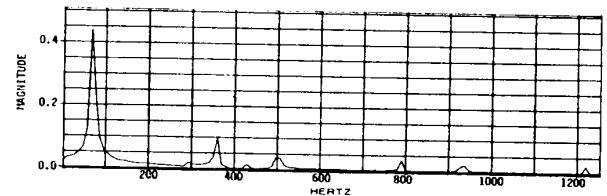
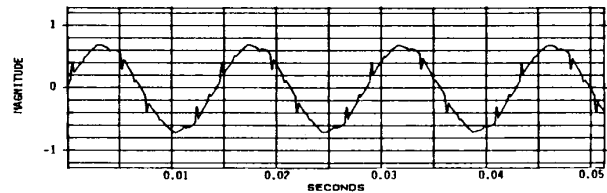

FIG. 10. CURRENT WAVEFORM AND ITS HARMONIC SPECTRUM FOR 6-PHASE SYNCHRONOUS MOTOR RATED AT 17 MW, 7200 V, 6000 RPM

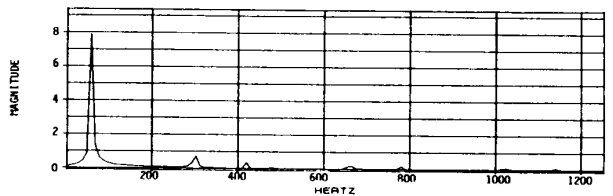
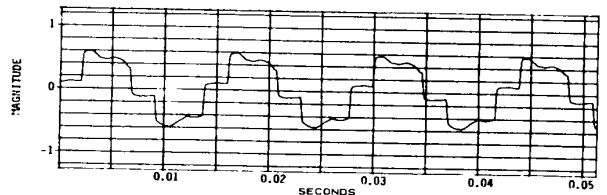
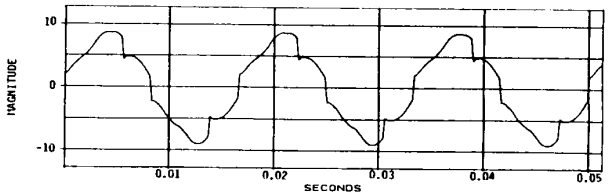

FIG. 11. CONVERTER TRANSFORMER SECONDARY CURRENT IN 12-PULSE SYSTEM



It is essential that lower order harmonic currents on the primary side be kept to a minimum in order to meet utility requirement for harmonic distortion factor. For this installation, Hydro-Quebec requirements for harmonic distortion factor at 230 KV is not to exceed 1%, and this was satisfied. The use of 12-pulse system and a special transformer arrangement substantially reduces the 5th and 7th harmonic currents. Harmonic currents may be further reduced by the use of filters connected to the primary side of the converter transformer. Harmonic filters are normally selected to perform two functions: To improve and maintain an acceptable power factor over the drive speed operating range and to limit the harmonic voltage distortion to permissible levels. In general, for 12-pulse system, it is not necessary to use a separate harmonic filter for each harmonic component. For this installation three filter branches were used. The first filter branch is tuned to 342 Hz in order to reduce both the 5th and 7th harmonic voltages at the incoming bus. The second filter branch is tuned to 702 Hz to absorb the 11th and 13th together, and the third filter branch is tuned to 1380 Hz to absorb the 23rd and 25th together. These filters are connected to 25 KV bus and located outdoor in the substation yard and occupy an area of 13.5 m x 7.5 m. Figs 12 and 13 show the waveforms of the incoming line current and the voltage at 25 KV bus. Both waveforms are almost sinusoidal and harmonic levels are within utility requirement. Fig. 14 shows the total current in the harmonic filters connected to 25 KV.

In the design of the filters, the possible failures of the individual capacitor cans and the corresponding increase in voltage had to be considered. The capacitor cans had to be small enough so that the failure of one or two cans would not jeopardize the function of the filters and lead to drive shutdown. With a selection of 100 KVAR capacitor cans, in a rack mounted arrangement, it was possible to tolerate the failure of two capacitors per filter branch before the filters had to be disconnected. The use of individual external fuses makes the visual inspection simple and failure easy to detect.

CONCLUSIONS

It is inevitable that harmonics will be generated whenever an adjustable speed drive is used. The order and magnitude of these harmonics greatly depend on the drive configuration and system impedance. A 3-phase machine connected to 6-pulse system will generate more harmonics when compared to a 6-phase machine connected to 12-pulse system. Harmonic losses in the stator and rotor must carefully be taken into account during design stages to keep motor temperature rise to acceptable limits. Harmonics fed back to the power system are reduced by the use of filters which are connected to the incoming power supply. These filters are relatively large and occupy substantial space in the substation yard.

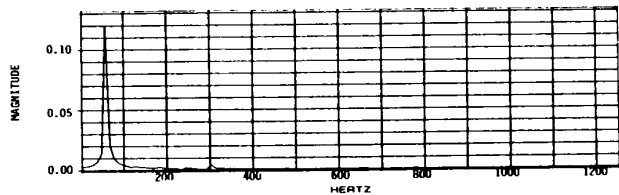

FIG.12. INCOMING LINE CURRENT TO 25 KV BUS.

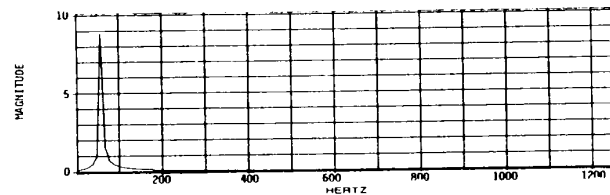
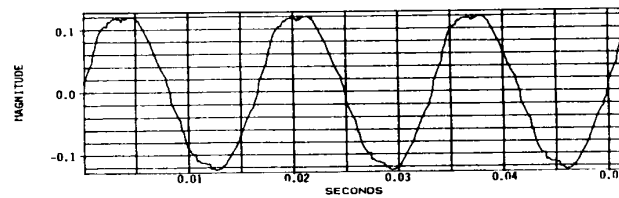

FIG.13. VOLTAGE AT 25 KV BUS WITH FILTERS CONNECTED.

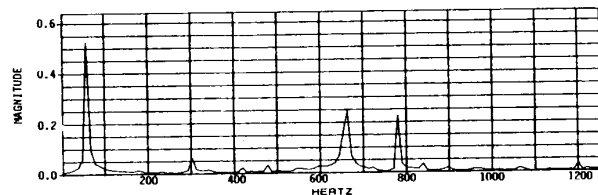
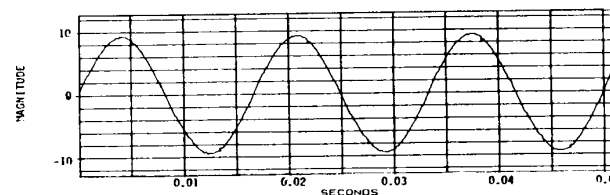
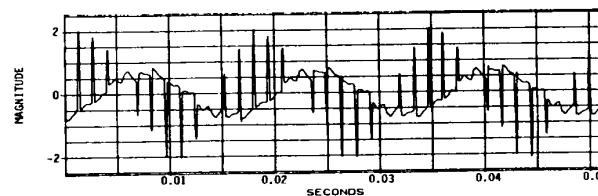

FIG.14. TOTAL CURRENT IN HARMONIC FILTERS CONNECTED TO 25 KV BUS.



There is a great need for a coordination of decisions regarding acceptable harmonic levels between users, drive manufacturers, electric utilities and standards groups. This would certainly simplify the requirements for harmonic filters from the user's and manufacturer's point of view.

REFERENCES

1. IEEE Standard 519-1981, "IEEE Guide for Harmonic control and Reactive Compensation of Static Power Converter".
2. Rice, D.E., "Adjustable Speed Drive and Power Rectifier Harmonics, their Effect on Power Systems Components". Paper presented at the 1985 Annual Meeting of the IEEE Industry Application Society.
3. Power System Relay Committee of the IEEE PES Report, "Sine Wave Distortions in Power System and the Impact on Protective Relaying", 84th 0115-6 PWR.
4. Day, A.L. and Mahmoud, A.A., "Methods of Evaluation of Harmonic Levels in Industrial Plant Distribution Systems". Paper presented at the 1985 Annual Meeting of the IEEE Industry Application Society.
5. Weiss, H.W., "Power Transmission to Synchronous Machines for Adjustable-Speed Pump and Compressor Drive Systems". Record of Conference Papers of the 29th Annual PCIC, 1982.
6. Hanna, R.A. and MacDonald, D.C., "The Six-Phase Generator and Transformer into a Three-Phase Power System". IEEE Transaction on Power Apparatus and System, August 1983.
7. Sisa, E.M., "17 MW High Speed Current Source Converter Drives". IEEE, Industrial Application Society Annual Conference, October 1987, page 360.
8. Cummings, P.G., "Estimating Effect of System Harmonics on Losses and Temperature Rise of Squirrel-Cage Motors" record of Conference Papers of the 32nd Annual PCIC, 1985.