

DESIGN CHALLENGES ENCOUNTERED WHEN EXPANDING A WORLD CLASS PETROCHEMICAL FACILITY

Copyright Material IEEE
Paper No. PCIC-2000-10

John Dickin, P.Eng
Member IEEE
NOVA Chemicals Corp.
P.O. Box 5006
Red Deer, Alberta
T4N 6A1

Dr. Robert Hanna, P.Eng
Senior Member IEEE
RPM Engineering
2816 Hammond Road
Mississauga, Ontario
L5K 2R1

Scott Randall, P.Eng
Member IEEE
NOVA Chemicals Corp.
P.O. Box 5006
Red Deer, Alberta
T4N 6A1

Chris Dedeurwaerder
Member IEEE
NOVA Chemicals Corp.
P.O. Box 5006
Red Deer, Alberta
T4N 6A1

Abstract - This paper describes the electrical design challenges encountered when adding a new ethylene plant, a polyethylene plant, a cogeneration plant, and associated utilities to the NOVA Chemicals Corporation, Joffre, Alberta site. It covers load estimation, power quality, reliability, common electrical specifications and project co-ordination with several major engineering, procurement, and construction firms. It also highlights the unique design and utility interconnection challenges of building Canada's largest cogeneration plant (rated at 420 MW) within an existing petrochemical plant. The challenges include transmission system capacity and connection, fault levels, stability, and voltage regulation. The paper makes recommendations based on the learning experienced during the implementation of this project, to assist the reader faced with a similar major plant expansion.

Index Terms — Power System Design, Power Quality, Cogeneration.

I. INTRODUCTION

NOVA Chemicals Corporation's Joffre manufacturing facility is located 10 miles east of Red Deer, Alberta, Canada and is considered one of North America's largest petrochemical complexes. The facility produces ethylene and polyethylene and is currently the second largest ethylene production site in North America.

Joffre site's first ethylene plant (E1) started production in 1979. The petrochemical complex has steadily expanded in the past 20 years to include a second ethylene plant (E2), a polyethylene plant (PE1) and hydrogen off gas plant. The facilities initial electrical demand was 10 megawatts and grew to 60 megawatts in 1999. The Joffre site was initially supplied from the transmission grid by two separate 138 kV overhead feeders. This was later expanded to include a third 138 kV overhead feeder.

In 1996, NOVA Chemicals Corporation announced plans to expand its Joffre site. In a joint venture with another major petrochemical producer, NOVA Chemicals will start up a third ethylene plant (E3) in the Fall of 2000. At the same time, NOVA Chemicals will start up a second polyethylene plant (PE2). To take advantage of the expanded facilities' large steam and electrical demands, NOVA Chemicals, in a joint venture with two major electrical utilities, is building a 420-megawatt natural-gas-fired cogeneration facility. The cogeneration plant is scheduled to come on-stream in 2000, in advance of the

start-up of the new petrochemical facilities. Finally, a third major petrochemicals producer is building an ethylene derivatives facility at the Joffre site. This project is expected to begin operations in the summer of 2001 and is managed by a third party. See Figure 1 Joffre Site.

Joffre site's electrical demand is expected to increase to 110 megawatts at the completion of the Joffre 2000 plant expansions. The Joffre facility will then be fed from the transmission grid by five 138 kV overhead lines.

In addition to NOVA Chemicals implementing the two process plant projects and the cogeneration plant project, a fourth project is implementing an expansion to the existing Joffre site utilities. This paper discusses the key challenges encountered during the term of these projects and makes recommendations based on the learning experienced.

II. COGENERATION PLANT

Several factors led to the decision to locate a large cogeneration plant at the Joffre site:

- The need to install additional steam capacity of at least 4 package boilers to provide steam to the new processes.
- A forecasted shortage of generation in the Province of Alberta.
- The favourable environment of the deregulated power market in Alberta.

The cogeneration plant sizes considered ranged from 100 MW to 420 MW. The largest size was chosen based on the economies of scale and increased efficiency the largest plant afforded.

The plant configuration, commonly referred to by the industry as a "2 on 1", consists of two gas turbine/generators with heat recovery steam generators and one steam turbine/generator. The gas turbines are natural-gas-fired, 170 MW units connected to 18 kV, 3600 RPM, 190 MW generators. The steam turbine is a 150 MW unit connected to an 18 kV, 3600 RPM, 140 MW generator. The steam requirement of the plant is the capacity of at least one gas turbine/steam generator. The second gas turbine/steam generator was installed to provide better reliability of the steam supply. Upon loss of all generation, backup power contracts are in place to cover power supplied from the Alberta transmission grid.

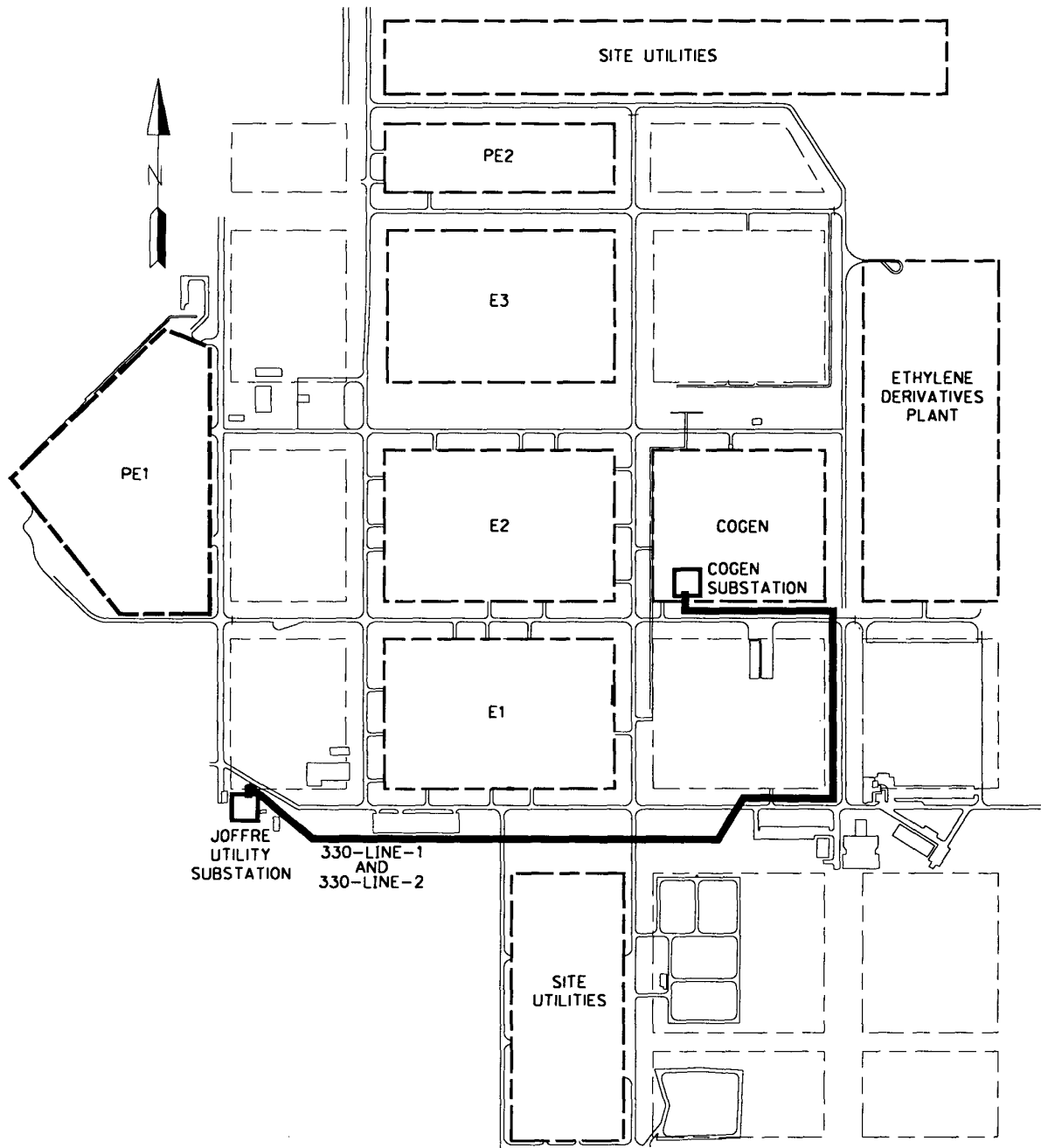

FIG. 1: JOFFRE SITE

138 kV System Short Circuit Capacity

The design short circuit current rating of the 138 kV system was not known until the preliminary design of the transmission system and the power system studies were largely complete. This caused some uncertainty in the early days of the design, as the 138 kV system design and specification of equipment could not be completed. The final design within the Joffre plant was for the 138 kV system to be designed to 28 kA, and equipment supplied meeting 31 kA.

The Utility, upon knowing the actual short circuit current available on the 138 kV system, checked the immediate area to ensure the actual equipment ratings within their system were adequate. In addition to the immediate area upgrade to manage the additional system load, six 138 kV breakers in three remote substations were found to be underrated even before the generation came on line. It was determined that these breakers were already destined to be replaced at some time in the future, so the cost was not included in the project cost.

Deregulation of Industry and Lack of Information

Being one of the first, and the largest cogeneration project to be built in Alberta and in the initial stages in a deregulated market, all parties had to determine their roles and responsibilities, many of which appeared to overlap.

Considerable time was spent researching the interconnection requirements, and in some cases when none were found, decisions were made based on what appeared to be the right thing to do. Specifically, the owner had to research the number of permits and licenses required, the technical interconnection specifications, design standards, Western System Coordinating Council requirements, and interconnection operating procedures and agreements.

One particularly interesting aspect was the need for the Joffre site to be designated with an Industrial Site Designation so that the transmission grid would recognize that energy consumed from its own generation was not part of the energy transmitted on the grid. Part of the Industrial Site Designation includes the Joffre Utility Substation.

Defining initial regulator exciter, and Power System Stabilizer Settings

At one time the generation was put in by fully integrated utilities, but with deregulation, certain services that were inherent in their organizations were not readily available to independent power developers. One service that had to be acquired from the Transmission Administrator was the system studies to determine exciter, governor and Power System Stabilizer settings. This was a challenge as not one particular group had the full accountability or all the information. A process where sharing of modeling information and results was implemented to ensure quality settings were in place for first synchronization.

Maintaining acceptable voltage regulation for the petrochemical plant

One of the benefits of a large generation plant within a complex is the ability to provide excellent voltage regulation using the generator Automatic Voltage Regulators when at

least one generator is on line. When the last generator trips, however, the voltage drop can be very large, removing the VAR voltage support. Studies were run to predict the maximum allowable VAR generation for all operating situations, i. e. number of generators on or off, predicted load, etc., so that the Joffre plant voltage on all the buses would be maintained at an acceptable level.

To minimize the effect of the anticipated voltage drop when the last generator trips off, an operating procedure is initiated to limit the VAR generation when only one gas turbine/generator is on line.

Operating Procedure Changes

Before a generation plant was on site, the interaction between the plant and the utility were minor in many respects. Notification of plant turnaround events, utility system line, breaker, or bus outages would be examples of routine interactions. Other interactions would be reviews of any significant system events that caused plant upsets or shutdowns. Examples of these would be voltage sags due to storm activity.

Plans for the interactions between the operations of the Joffre site and the utility will now also include daily generation nominations and generator availability, planned or unplanned generation shutdowns, implementing voltage regulation procedures, implementing generation capacity reductions due to utility system element outages, and line reclosing, both planned and unplanned.

III. LOAD AND GENERATION ESTIMATION

One of the design processes that all engineering, procurement and construction (EPC) companies handled similarly was their estimation of plant electrical loads. The first step was to set up a load list in a spreadsheet format. The initial data for this load list was derived from the draft process and instrumentation diagrams, and typically consisted of only the horsepower required for the motor. This data was reviewed by the EPC's electrical design group and then other loads were added at this point, such as lighting, heat tracing, receptacles, HVAC, process computer power requirements and other necessary loads.

The summation of these loads was used to produce the initial average and peak load estimates in terms of MW and MVA required. The average load was defined as the statistical average of the load over the operating period, with the plant considered as fully operational. This "commercial load" was used to determine the allocation of power distribution costs and to ensure that power rates chosen were appropriate for the load.

The peak load was the highest load anticipated and was used to set the maximum equipment sizing for the power system. This "engineered load" took into account the highest load used when the plant was at peak production with the greatest demand requirements or upset/abnormal conditions.

It is important to note that the "engineered" and the "commercial" electrical loads were different. This resulted in a challenge during the design stage since the engineered load needed to be sized to ensure proper equipment rating, while the commercial load needed to be sized to reflect a realistic allocation of the shared power distribution system and to not result in peak demand penalties.

To provide the required generation export, the existing and future plant loads were analyzed in order to determine loads during planned, unplanned, full and partial shutdowns. The main challenges were in making a realistic model for the plant loads, since plants can partially or fully shut down unexpectedly. The future plants were even more difficult to model, since there was no historical support data.

The decision was made to maximize the transmission system export capabilities without ambient temperature constraints. The generation capability was limited during the summer since gas turbines operating at a higher temperature have a lower output than in the winter months. An analysis was done to determine the frequency of occurrence of temperatures throughout the year. As expected, a bi-modal curve was produced. The temperature ranged from -44°C to 32°C and the two resulting temperature peaks were at 0°C and 12°C.

IV. POWER QUALITY STUDY

A power quality study was carried out to determine the level of harmonics within the plant, ensure compliance to the utility requirements at the point of common coupling (PCC) at 138 kV and meeting the IEEE 519-1992 standard for harmonic guidelines [1]. The study also identified if harmonic resonance existed and if filters were required to meet the harmonic guidelines. Commercially available software was used to calculate the voltage total harmonic distortion (THD) and current THD and IT product throughout the plant. (The IT product is a factor that recognizes the interference between harmonics generated by non-linear load and the communication circuits in the proximity of power lines). A model was developed covering the linear and non-linear loads for the entire Joffre plant. The non-linear load in the new plants comprised of medium voltage adjustable speed drives (ASDs) and low voltage ASDs. The non-linear loads in the existing plants consisted mostly of DC drives.

Figure 2 shows a simplified single line diagram for the entire Joffre facility. All new medium voltage ASDs were of 30-pulse design to suppress harmonics at the source. Low voltage ASDs were of a 6-pulse design producing lower order harmonics. There was a total of 5 medium voltage ASDs, with the largest being 7240 hp for an extruder application. There was a total of 14 low voltage ASDs rated at 400 hp and 350 hp. All low voltage ASDs were purchased with 5% input line reactors to reduce the susceptibility to transient over-voltage.

Two main cases were thoroughly studied to determine the harmonic levels. The base case covered an operating condition with the entire Joffre plant fed from the utility power with the cogeneration plant out of service. This case was analyzed when the utility capacitor bank was on-line and when it was off-line. The second case assumed that the new plants are fed from the cogeneration plant with one generator in service.

The following assumptions were made to carry out harmonic study:

- a) The plant input data and system configuration were based on the load flow study and short circuit study. The MVA short circuit level was calculated at all buses without motor contribution.
- b) The utility harmonic impedance profile was modeled based on the harmonic spectrum provided by the utility.
- c) All ASDs were assumed running at rated load and rated speed for maximum harmonic generation.
- d) The current spectrum for medium voltage ASDs was based on measurements taken during factory acceptance tests rather than the typical published values.
- e) The electric heaters were assumed not to produce any harmonics.
- f) Typical harmonic spectrum was used for all existing DC drives.
- g) The harmonic spectrums for all low voltage ASDs were obtained from the manufacturers.
- h) All linear loads at 600 V and at 4160 V were combined where ASDs were connected.
- i) Cable impedance at 13.8 kV and at 138 kV was included.
- j) The electrical demand for the existing plants was based on the utility power billing for the previous last 12 months. For the expanded new plants it was estimated from the load flow calculations.

The results of the harmonic study for the base case are summarized in Table 1 which lists the values of current THD, voltage THD and IT product at all 13.8 kV levels and at 138 kV for the new and existing plants. Also, the values of harmonics at 4.16 kV and 0.6 kV buses having connected non-linear loads is shown. Each new process plant having non-linear load was made accountable to meet the IEEE harmonic requirements at PCC, which was selected at 13.8 kV.

The short circuit ratio (SCR) shown in Table 1 is equal to the short circuit current without motor contribution divided by demand load. The higher the SCR the more relaxed is the IEEE standard requirements. The capacity of a utility is defined by the short circuit current at PCC. The size of a plant is defined by the maximum demand load. Table 1 also lists the levels of harmonic limitations as specified in IEEE 519-1992 standard. It can be seen that the entire Joffre plant complies with IEEE 519-1992 harmonic requirements at 138 kV utility bus. Also, all new plants do comply with the harmonic limits at 13.8 kV. However, harmonic levels at the E3 ethylene plant at 4.16 kV and at 0.6 kV exceed the IEEE limits because of the presence of six pulse ASDs. In spite of this, it was decided not to install any harmonic filters, as it is believed that these harmonics should not cause significant overheating in motors at E3 plant. The step down transformers 13.8/4.16 kV for the E3 plant were all purchased suitable for non-linear load.

The harmonic study also revealed that no resonance existed because there were no capacitors throughout the Joffre plant. The IT product was calculated at 138 kV and found to be 3155 which is well within the IEEE requirements.

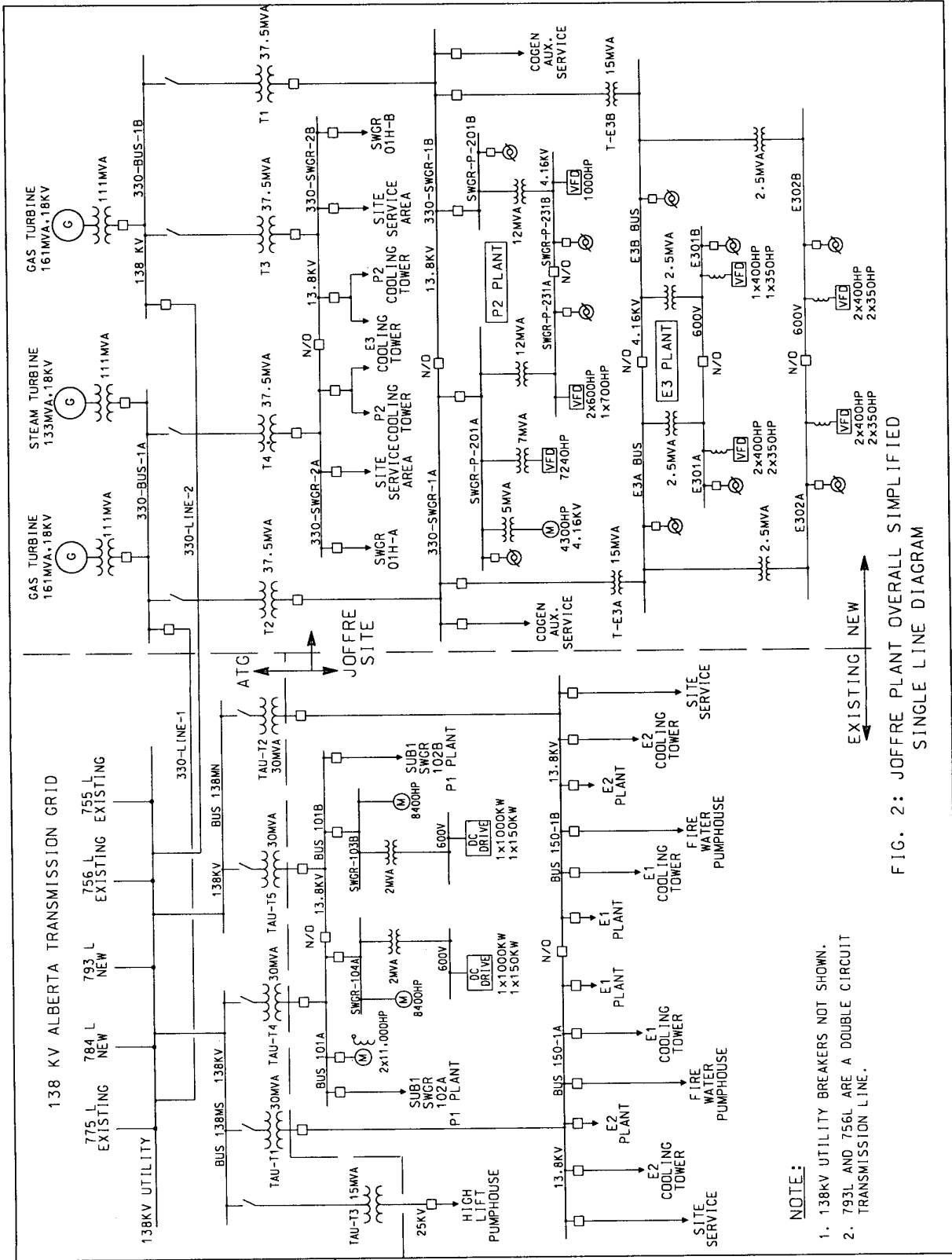

NOTE:

1. 138KV UTILITY BREAKERS NOT SHOWN.
2. 793L AND 756L ARE A DOUBLE CIRCUIT TRANSMISSION LINE.

FIG. 2: JOFFRE PLANT OVERALL SIMPLIFIED SINGLE LINE DIAGRAM

TABLE 1
HARMONIC SUMMARY FOR NEW AND EXISTING PLANTS
UTILITY POWER ONLY, GENERATOR OFF-LINE, UTILITY CAPACITORS OFF-LINE

Bus ID (New Plant)	Short Circuit Ratio	Demand (A)	VTHD (%)	V-IEEE Limit (%)	ITHD (%)	I-IEEE Limit (%)	I*T	IT-IEEE Limit
330-BUS-1A / 138 kV	50.2	193	0.23	2.5	1.09	6.0	1,997	10,000
330-BUS-1B / 138 kV	66.6	145	0.23	2.5	1.58	6.0	1,470	10,000
330-SWGR-2A / 13.8 kV	17.7	816	0.19	5.0	0.14	5.0	3,729	10,000
330-SWGR-2B / 13.8 kV	23.3	613	0.20	5.0	0.16	8.0	3,238	10,000
SWGR-01H-A / 13.8 kV	36.0	372	0.19	5.0	0.16	8.0	1,975	10,000
SWGR-01H-B / 13.8 kV	45.9	287	0.20	5.0	0.17	8.0	1,739	10,000
330-SWGR-1A / 13.8 kV	13.0	1111	1.05	5.0	1.94	5.0	21,867	10,000
330-SWGR-1B / 13.8 kV	17.3	833	0.97	5.0	2.79	5.0	16,295	10,000
SWGR-P-201A / 13.8 kV	23.0	585	1.03	5.0	1.71	8.0	10,479	10,000
SWGR-P-201B / 13.8 kV	37.6	337	0.98	5.0	0.82	8.0	4,824	10,000
SWGR-P231A / 4.16 kV	33.7	539	1.12	5.0	1.60	8.0	9,539	10,000
SWGR-P231B / 4.16 kV	27.4	655	1.03	5.0	0.89	8.0	8,697	10,000
E3A / 4.16 kV	16.8	1221	2.90	5.0	8.43	5.0	87,411	10,000
E3B / 4.16 kV	22.5	907	2.38	5.0	8.64	8.0	70,286	10,000
SWGR-E301A / 600 V	17.7	1845	8.76	5.0	20.04	5.0	49,854	10,000
SWGR-E301B / 600 V	40.6	798	5.22	5.0	23.51	8.0	26,111	10,000
SWGR-E302A / 600 V	21.2	1536	8.75	5.0	24.36	8.0	51,774	10,000
SWGR-E302B / 600	24.4	1324	8.26	5.0	28.54	8.0	53,417	10,000
Bus ID (Existing Plant)								
Utility / 138 kV	15.8	634	0.23	2.5	0.30	2.5	3,155	10,000
Bus 101A / 13.8 kV	12.4	1163	0.55	5.0	1.27	5.0	10,239	10,000
Bus 101B / 13.8 kV	22.4	648	0.58	5.0	2.35	8.0	12,172	10,000
SWGR-104A / 13.8 kV	39.4	366	0.55	5.0	4.17	8.0	13,236	10,000
SWGR-103B / 13.8 kV	42.0	346	0.58	5.0	4.47	8.0	14,001	10,000
SUB1-SWGR-102A / 13.8 kV	61.5	234	0.55	5.0	0.46	12.0	2,404	10,000
SUB1-SWGR-102B / 13.8 kV	51.4	282	0.58	5.0	0.48	12.0	3,156	10,000
BUS150-1A / 13.8 kV	26.1	560	0.19	5.0	0.16	8.0	3,107	10,000
BUS150-1B / 13.8 kV	29.2	504	0.19	5.0	0.16	8.0	2,861	10,000

V. RELIABILITY

The reliability of the existing transmission system supplying the Joffre site has been very good to date. Only two events causing a total shutdown have been recorded in the 20 years since the Joffre site first came on line. It was a goal of this project to maintain a similar level of reliability after the expansion was complete. The project benchmark was that any loss of a system component causing the petrochemical plant to have to reduce electric consumption was considered a failure to serve the load. One key challenge was providing a transmission system that would both import and export energy. Since the Joffre site would be a net exporter, it was decided that if the reliability for export was met, then the reliability for import would also be fulfilled.

A transmission system's capability to provide reliable electric power to the load and reliable export power was evaluated in two ways. First it was evaluated to determine the system adequacy, or the reliability of the system configuration and capacity in order to provide the physical

connection between the load, generation and the Alberta transmission grid. Next, the system security or ability to respond to power quality disturbances that influence the entire transmission grid was evaluated.

The following combination of methodologies and techniques were used to determine the reliability: Reliability Network Reduction, Failure Mode Effects Analysis, Minimal Cut Set Method, and Hierarchical Level Indices Technique. References [2] and [3] provide a detailed discussion of these techniques. The results of the analysis are summarized in Table 2.

System Adequacy

A risk review was done of the entire transmission system to identify single point failures that might affect the export of power from the cogeneration plant. The utility and cogeneration substations were then designed to address these single point failures. If elimination of a single point failure was not achievable, appropriate operating

procedures were developed with the utility to ensure that one failure would not affect the export.

Two cases were identified as single point failures. The first was the 138 kV double circuit overhead line configuration of lines 330-Line-1 and 2, connecting cogeneration busses 330-BUS-1A and 1B and the utility substation. The second was the utility 138 kV double circuit overhead line configuration of lines 756L and 793L. To manage the failure risk of lines 330-Line-1 and 2, the lines were designed to maximize the reliability, as outlined in Section VII. For lines 756L and 793L, the lines follow a known route that has minimal road access to reduce vehicular impacts, and follow a route of lower elevation from the surrounding terrain making it less susceptible to lightning strikes. To prepare for the possibility of a coincident outage on this double circuit line, operating procedures will be implemented to ensure the cogeneration plant operators recognize the possible overload condition on the remaining lines and reduce the export load.

Corporate separation between the generators, the transmission system, and the loads close to the Joffre plant, and the lack of full system visibility of the transmission grid by the cogeneration plant operator, hampered the development of automatic remedial action schemes. These schemes would have helped limit generation upon loss of load. Therefore, the design of the transmission system had to be robust enough to allow unplanned outages to occur that would not immediately affect the cogeneration production or overload the remaining system, until the cogeneration and transmission grid Operator could reduce generation to allow for the outage.

In the event of islanding, the situation where some or all of the Joffre load is being served by the Joffre site generation with no connection to the transmission grid, adequate equipment and controls were installed to allow for re-synchronization back to the grid.

System Security

Results determined that the largest affect to both importing and exporting power from the Joffre site was the system security impacts. There were three main components of system security risks identified. The first risk, system voltage collapse due to shortage of VARs, was determined to have a frequency of 0.08 occurrences per year. The second risk, frequency instability due to loss of major blocks of generation on the Alberta transmission grid, has a frequency of 0.016 occurrences per year. Finally, the third risk, the threat of a major storm disabling large parts of the Alberta transmission grid, has frequency of 0.034 occurrences per year.

TABLE 2
FREQUENCY OF EVENTS CAUSING FAILURE
TO SERVE LOAD OR GENERATION
OF THE JOFFRE SITE

	System Adequacy Freq/Year	System Security Freq/Year	Total Freq/Year
Plant Load	0.001	0.13	0.131
Export Generation			
Summer Average	0.006	0.13	0.136
Winter Average	<0.001	0.13	<0.131

Maintaining Reliable Service for Existing Plants during Modifications to the Transmission Grid

Due to the risk associated with such extensive modifications to the transmission system feeding the existing Joffre plant, the utility used an internal risk management plan to ensure the risks were identified and safe work procedures were put in place. The Failure Mode Effect Analysis (FMEA) process allowed the project to review the risks associated with each segment of the work and put safe work plans in place for each. The safe work plans assisted in minimizing the chance of failure, but should an event happen, they also provided a means to manage the problem.

VI. POWER SYSTEM STUDY

A power system study was carried out for the entire Joffre plant and it covered the load flow, short circuit, motor starting and stability studies. Figure 2 shows the Single Line Diagram. Numerous cases were studied to determine the system performance under normal and abnormal operating conditions. A commercially available power system analysis and design program was used to model and predict system response. The model was developed based on the information and drawings provided by the plant and equipment vendors. The equivalent impedance of each 138 kV incoming transmission line was modeled on the maximum available three-phase and single-line to ground symmetrical short circuit current provided by the power utility. Under normal operation, all three generators are in service to meet the total plant power requirements and to export the balance. Design criteria were set for the power system studies and these included:

- Steady state voltage regulation at 13.8 kV to be within +3%, -2%.
- 13.8 kV short circuit capacity to be 400 MVA with tie breaker open and 800 MVA with tie breaker closed.
- Maximum voltage drop at bus during motor starting not to exceed 12% assuming all load on one bus with tie breaker closed and one transformer out of service.
- Overall plant power factor 90% or greater.

Short Circuit Study

The short circuit calculations were performed based on the ANSI/IEEE C37 standard for circuit breakers, switchgear, substations and fuses. Two different impedance networks were used to calculate the momentary and interrupting three phase short circuit currents and the result compared with the corresponding ratings for high and low voltage switchgear circuit breakers. The ½ cycle network (sub-transient impedance network) was used to calculate momentary short circuit current duties at ½ cycle after the fault had occurred. The 1.5-4 cycles network (transient impedance network) was used to calculate the interrupting short circuit current duties at 1.5-4 cycles after the fault had occurred. The entire plant was modeled as 150 buses, 149 branches and 152 motors of which six were synchronous motors and three were generators. The pre-fault bus voltage was assumed at 1.05 per unit. The contractor and the in-house project team co-operated in establishing the cases to be studied. Five short circuit case studies were performed covering various scenarios of system configuration in order to determine the maximum fault current. Two cases are listed here which describe the base

case and the worst case. The base case designated short circuit case #1 (SC1) covered the normal operating condition with the plant connected to five 138 kV utility lines, cogeneration on line and tie breakers at all voltage levels open. The result of the short circuit study is given in Table 3, which also includes the breaker three phase symmetrical interrupting and momentary rating in kA. The short circuit case #2 (SC2) covered a condition whereby the 13.8 kV tie breaker for cogeneration bus 330-SWGR-2A and 330-SWGR-2B is closed. This implies that the two

37.5 MVA step down transformers T3 and T4 are connected in parallel thus providing minimal impedance. It can be seen that the short circuit levels are within the breakers interrupting and momentary rating except for the 13.8 kV incoming breakers to bus 330-SWGR-2A and 2B. It was decided not to upgrade these two breakers because operation of two transformers in parallel will only occur for a short period of time to allow seamless transfer of power between the two transformers.

TABLE 3
Summary of short circuit study for the new plant showing 1.5-4.0 cycle three-phase Interrupting (INT) and ½ cycle three-phase Momentary (MOM) Values in kA.
It also shows the circuit breaker three-phase Interrupting and Momentary rating

BUS NAME (ID)	CASE SC1		CASE SC2		CIRCUIT BREAKER RATINGS	
	INT (kA)	MOM (kA)	INT (kA)	MOM (kA)	INT (kA)	MOM (kA)
Utility / 138 kV	22.2	35.1	22.2	35.2	-	-
330-SWGR-1A / 13.8 kV	20.2	32.3	20.2	32.3	30.4	58
330-SWGR-1B / 13.8 kV	19.8	31.4	19.9	31.6	30.4	58
330-SWGR-2A / 13.8 kV	19.1	30.0	37.5	60.3	30.4	58
330-SWGR-2B / 13.8 kV	20.8	33.7	37.5	60.3	30.4	58
SWGR-01H-A / 13.8 kV	16.1	24.4	29.3	41.2	40.2	77
SWGR-01H-B / 13.8 kV	17.9	28.8	29.9	44.4	40.2	77
SWGR-P-201A / 13.8 kV	17.0	26.4	17.0	26.4	30.4	58
SWGR-P-201B / 13.8 kV	17.0	23.1	15.9	23.3	30.4	58

Load Flow Study

The load flow study was conducted for normal and abnormal system configurations. The intent of this study was to determine electrical loading of main feeders, transformers and bus voltage under different operating conditions and to study the effects of changes in equipment configuration. The base case is designated LF1 and is identical to that of short circuit study SC1. The total plant load for the new process units was estimated at 105 MVA and for the existing units was 82 MVA. The cogeneration plant is connected to the utility at 138 kV via 2 KM of two over head lines, 330-Line-1A and 2A. For load flow case LF1, the power carried by Line-1A was 257 MVA and by Line-2A was 124 MVA. Four more load flow studies were carried out covering possible scenarios but only one abnormal case is presented here. Load flow case LF2 represented a scenario that was identical to LF1 except the cogeneration plant was operating in an islanded mode with one gas turbine generator (161.5 MVA) in service. This implies that the existing plant was supported by utility power and the new plant by one generator with the two 138 kV lines (330-Line-1 and 330-Line-2) between the cogeneration plant and utility out of service. In addition, it was assumed that the 13.8 kV main breakers to buses 330-SWGR-1B and 330-SWGR-2B are open and to buses 330-SWGR-1A and 330-SWGR-2A are closed as well as the tie breakers between Bus A and Bus B are closed. The results of load flow study for selected cases LF1 and LF2 are given in Table 4. It can be seen that the design criteria of +3% and -2% was met for the base case but exceeded for load flow LF2. The worse case was at buses SWGR-P-201A and SWGR-P-201B whereby the voltage was reduced to 94% of nominal value. The result of the

load flow study for all scenarios revealed that the electrical load was within the cable and transformer ratings.

TABLE 4
Summary of Load Flow Study for the New Plant

BUS NAME (ID)	Calculated Bus Voltage (% of Nominal Bus Voltage)	
	CASE LF1	CASE LF2
Utility / 138 kV	100.000%	100.000%
330-SWGR-1A / 13.8 kV	100.099%	94.439%
330-SWGR-1B / 13.8 kV	100.304%	94.439%
330-SWGR-2A / 13.8 kV	100.618%	95.385%
330-SWGR-2B / 13.8 kV	100.573%	95.385%
SWGR-01H-A / 13.8 kV	100.487%	95.247%
SWGR-01H-B / 13.8 kV	100.159%	94.946%
SWGR-P-201A / 13.8 kV	99.700%	94.036%
SWGR-P-201B / 13.8 kV	100.020%	94.150%

Motor Starting Study

The motor starting calculations were performed to determine compliance to design criteria of maximum 12 % voltage dip set for the new plants during motor starting under various operating conditions. The study was based on estimated values of motor and transformer sizes, as these were not firmed at the design stage. The largest direct on line induction motor for the new plant is rated 4300 hp connected to SWGR-P-201A (13.8 kV) via a captive transformer. The largest induction motor in the existing plant is rated 8000 hp and is connected to bus SWGR-104A at 13.8 kV. Several scenarios were

evaluated when the entire Joffre plant was connected to the utility power and when it was fed from the cogeneration. The worst case was when the entire Joffre plant was fed by a single generator (161.5 MVA) in an islanded mode (utility out of service) and starting the 8000 hp motor in the existing plant. In this case, the motor starting voltage dip was calculated at 17% at 13.8 kV (SWGR-104A) and this is above the design criteria. However, the maximum voltage dip for this case for the new plant at 13.8 kV (SWGR-P-201A) was 7% and this is within the design guideline for the new plant. For the existing plant, it was decided to tolerate 17% motor starting voltage dip because the likelihood of this situation arising is very rare.

VII. ELECTRICAL DESIGN PHILOSOPHY

During the initial stages of the expansion projects it was decided to develop a common electrical design philosophy to be used by all EPC firms involved on the Joffre 2000 expansion. This design philosophy would incorporate some existing site philosophies, some common EPC philosophies and leading-edge industry philosophies. These design philosophies would in turn be used to develop common electrical standards and specifications across all projects. By having common standards and specifications, the projects were able to leverage electrical equipment purchases.

Power Distribution Design Philosophy

The purpose of the electrical system protection and coordination was to prevent injury to personnel, to minimize damage to the system components, and to limit the extent and duration of service interruption whenever equipment failure, human error, or adverse natural events occur on any portion of the system. It would also ensure that maintenance could be safely performed on the electrical distribution equipment without causing or requiring a power interruption.

The power distribution system was designed to employ a dual feed philosophy at the primary distribution level of 13.8 kV and a secondary selective philosophy at the 4.16 kV, and 600 V levels. The 13.8 kV, 4.16 kV and 600 V switchgear all incorporate a main-tie-main automatic transfer system with an open tie breaker scheme. The benefits and features of this design scheme are documented in Reference [4].

Protective Relaying/Power Monitoring

The protective relaying and power monitoring standard was to use modern microprocessor based devices, rather than the traditional induction disc types. The Joffre site's experience with the reliability and repeatability with these types of devices had been very positive, resulting in strong support for their site wide installation. Not all EPC electrical design personnel supported this position so it was a challenge to ensure that each EPC followed the above power monitoring and protective relaying standard. In most instances the owner was successful in implementing these common standards.

The installation of these microprocessor based devices made it possible to set up a network and bring data from these devices to one central location. Because of the high capital cost, it was decided to leave the installation of communication cabling between relays for future

connection. However, critical information such as breaker status is sent to the control room via a PLC system.

An extensive power monitoring system was installed to support electrical power billing by the cogeneration plant and the allocation of power costs across the site. A revenue quality system was designed and installed where metering data was gathered from four central locations and transmitted to a metering/billing computer system. All meter data is verified and allocations are calculated based on rates and contracts set for each operating plant.

One challenge was designing a protection and control system that allowed for both import and export of power while maintaining the same level of protection for the system.

The protection and control design of the existing 138 kV utility system followed the utility "standard" protection philosophy based on that voltage classification. The "138 kV" protection philosophy was based on primary and backup protection concept with slow clearing in event of single protection failure, which is generally applied for local area transmission and distribution to medium and large industrial plant loads. The owner was successful in having the utility philosophy upgraded to the "240 kV" protection philosophy based on plant and system consequences of protection failure with export of major cogeneration plant and import to very large industrial load. The "240 kV" protection philosophy is based on dual redundant primary protections with high speed clearing maintained in event of single protection failure.

The owner found itself in the position of having to coordinate and facilitate between many parties so that an acceptable design was achieved. All parties, the Utility, the cogeneration contractor, and the other four project contractors, had to understand the others' philosophies and look for reasonable compromises to their design so that all could be accommodated.

The primary protection on the 138/13.8 kV transformers followed industry practice by using transformer differential protection. Overcurrent protection is used as a backup for this differential protection. The trip and lockout scheme for the overcurrent relays are used to provide true redundancy between the separate trip and lockout scheme from the transformer differential relay. The non-electrical transformer protection was combined with the overcurrent protection, to provide two separate, independent, high speed tripping packages.

Again, for the 138 kV overhead transmission line, industry practice was followed. The breaker failure protection is used to provide backup protection for the self-reset tripping relays. The primary protection on the 138 kV overhead line between the cogeneration substation and the utility substation is dual differential protection and communicates via the fiber optic ground wire. The overcurrent line protection is used to provide backup protection for the 138 kV overhead line between cogeneration and the utility substation and the utility 138 kV buses and transmission grid lines. This will only trip the 138 kV line breaker in the cogeneration substation. Backup for this relay is provided by similar protection at the utility substation.

In the process plants, critical motors are provided with contactors that have an undervoltage ride-through circuit that will keep the motor connected to the bus for up to 2 seconds in the event of a plant voltage dip. Tests will be carried out during commissioning to determine the motor

open circuit voltage decay curve to ensure that motor damage cannot occur on re-start

During power outages of less than 10 seconds, critical motors are programmed to re-start automatically. This requirement is necessary since it can take up to 6 seconds for an automatic bus transfer to occur on a bus failure. The key challenge here was to ensure that the critical motor re-starts are sequenced.

Switchgear & Motor Control Centres

In the case of 13.8 kV and 4.16 kV indoor switchgear it was decided to deviate from the site standard of metal-clad and move to arc resistant switchgear. The increased safety of this switchgear far outweighed the increased cost.

The cogeneration substation's 13.8 kV switchgear was specified as indoor Class B arc resistant type. The 13.8 kV distribution equipment inside the process plants utilize outdoor, metal enclosed, fused disconnect switches. The 4.16 kV switchgear is indoor Class B arc resistant design. The 4.16 kV motor control centres (MCC) are of the draw-out vacuum contactors equipped with current limiting fuses type.

The 600 V motor control and distribution feeders utilize MCCs located indoors in an acclimatized environment with draw-out type starters equipped with HRCII, Class C fuses for motor control and HRCI, Class J fuses for distribution feeders. The Joffre site standard of using fused disconnects is based on the fact that they operate quicker than a circuit breaker, thereby providing better personal protection and less damage should a fault occur. Another advantage of fused disconnects is that they are easier to co-ordinate. A disadvantage of fuses is that they must be replaced, whereas a circuit breaker can be manually reset, potentially resulting in increased downtime.

Provisions to start the motor from the front of the 4.16 kV motor controllers are not provided so as to protect personnel from electrical flash hazard, by only allowing remote motor starting or remote switching from a mimic panel. The mimic panels are designed as free standing panels that house hand switches and status indicators for all 13.8 kV, 4.16 kV and 600 V breakers as well as for the 4.16 kV motor starters. They are incorporated in a graphic single line diagram on the front of the panel. Even though arc-resistant switchgear is made to protect personnel from electrical flash-overs, site safety guidelines still required the project team to utilize mimic panels.

138 kV Overhead Line Design Philosophy

The Joffre site 138 kV overhead lines, 330-Line-1A and 330-Line-2A are another example of a balance between maximizing reliability and minimizing capital costs. This overhead line connects the existing substation (and thereby the Alberta Transmission Grid) to the new cogeneration substation. Refer to Figure 2 Single Line Diagram – Joffre plant. One of the most difficult design challenges encountered was routing a high voltage line through a petrochemical facility, where many areas are classified as hazardous. An additional challenge was to provide a reliable and cost-effective system.

Both underground and overhead installations were investigated. An underground route proved to be prohibitive in both implementation and cost. Once the site personnel were convinced that an overhead line was the only feasible alternative, the design began.

Many studies were performed to assess the safety hazards, reliability, grounding requirements, the probability and impact of a lightning strike and other site impacts of installing a high voltage overhead power line in the middle of a petrochemical facility.

After numerous consultations, it was decided to use a double circuit 138 kV overhead line with two composite fiber optic ground wire cables and a single steel galvanized mono-pole base. Steel poles were used to alleviate concern raised by site personnel that wooden poles might catch fire should an explosion or fire occur on the site.

It was built to 240 kV specifications, which included heavy ice and wind loading, upgraded insulators, additional grounding at the base of the tower, upgraded ratings on the ground wire and higher ground clearances. It should be realized that the design of this overhead line occurred around the time of the major ice storm in Quebec, Canada. Site personnel were very sensitive to a design that would not withstand a major ice storm. A single pole was used because it was found that the reliability of the line was similar to using two poles.

Despite the additional design enhancements for the transmission line there were many concerns from the existing site personnel around possible contact of large machinery with the line, routing of the overhead line and the uncertainty around the effects of electromagnetic fields (EMF). These concerns were alleviated by education and design enhancements. Warning marker wires were installed at all road crossings to protect against machinery hitting live lines. The routing of the line was done to avoid all hazardous areas, even for the case where the line fell down. The EMF concerns were addressed by citing numerous studies, routing the line through unpopulated areas of the plant and meeting with plant personnel.

Above ground vs. Underground Cabling

One design philosophy that addressed the reliability of the plants was whether or not the electrical and instrument cabling would be above ground in cable tray or underground.

In the past, the Joffre site had installed power distribution cabling, motor feeder cabling and instrument cabling using direct burial and cable duct installation practices. One of the challenges was in changing the site standard of underground cabling. By installing cabling underground, the Joffre site Loss Prevention Standard's concern for fire and explosion hazard protection could easily be met. Unfortunately, this practice compromised the reliability of power to the plants since frequent frost heaves and thaws lead to numerous cable faults. A fault in an underground cable would require an extended outage to a plant while the fault was located, exposed and then repaired. Another reliability issue encountered was the deterioration of the direct buried cables that were exposed to hydrocarbons. Some further advantages to installing the cables in cable tray on the top of pipe racks are as follows:

- a) The sizing of distribution cables could be decided later into the detailed design. Since the installation timing of underground cabling is earlier in the design, there is a potential to install over sized cables to ensure project requirements are met.
- b) It is easier and normally faster to locate and repair damaged cables in a cable tray than underground cable.
- c) Power cables do not have to be de-rated in a cable tray (assuming adequate spacing is maintained) resulting in

smaller and more economical cables being installed than would be required in a direct buried installation.

One disadvantage to a cable in tray installation is that the fire and explosion risk exposure is greater than in an underground installation. To minimize these risks, industry standards were used to protect the cable trays. Critical instrumentation cabling was either routed outside fire hazard areas or was protected by heat shields in high fire risks areas. The existing polyethylene plant used cable in tray on a piperack raceway and history has shown that this installation is safer and more reliable.

Hazardous Area Classification

One challenge facing the Joffre 2000 projects was the classification of hazardous locations and the installation of electrical equipment in these locations. In 1997, the Canadian Electrical Code (CEC) was in the process of adopting the IEC approach to area classification which would give user's the ability to select North American or IEC equipment, or a combination of the two [5]. Since this approach to area classification was new to some of the EPC's electrical design personnel, numerous discussions and seminars were required before the IEC system was adopted for use on the Joffre 2000 projects. The main advantages to using this method of area classification are as follows:

- Many more methods of protection available for Zone 1 locations
- Provides the EPC the option to choose between the existing class and division rated equipment and wiring methods and/or the IEC rated equipment and methods or a combination of the two
- Allows the EPC to take advantage of any economic benefits that may exist by using the IEC system

Another reason for adopting the IEC method of area classification was that the 1998 CEC required all new construction to use this method. Even though the Joffre 2000 projects were started before the CEC had adopted this new method of area classification, the above advantages supported this direction.

Though an in-depth study has not been performed, project experience seems to indicate that there aren't any substantial cost savings in the purchase of the increased safety devices allowed by the IEC system. However, it is believed that there will be savings in installation costs.

Finally, there didn't appear to be a downside to adopting the IEC standard of area classification as the EPC's retained the option of using the old practices of Class and Division, if required.

VIII. PROJECT COORDINATION

The magnitude of the Joffre 2000 project resulted in the decision to use multiple engineering, procurement and construction (EPC) firms to implement the engineering design, procurement and construction. Separate EPC firms were retained for each of the following projects: E3, PE2, Cogeneration plant and the existing site utility expansion.

The challenge was to get each EPC to use similar engineering standards and specifications for equipment and installations. This proved to be a challenge as each EPC had its own preferred equipment vendors and installation details.

To add to this challenge, the cogeneration project was built under a lump sum contract so the owner's input was limited.

With the Joffre site in the midst of developing cross company standards, the owner decided to revise one of the EPC's existing standards and specifications by incorporating owner and industry practices into them. The result was common electrical design philosophies across all projects. In the end, the EPCs influenced the standards and specifications in such a way that some inconsistencies do exist.

Ultimately, it was feasible to use common equipment vendors with each EPC making minor changes to the equipment specifications. These specification changes resulted in some confusion to the equipment vendors, but generally the impact was manageable.

IX. CONCLUSIONS AND RECOMMENDATIONS

The Joffre plant underwent a major expansion that resulted in building a new ethylene plant, a polyethylene plant, a cogeneration plant, and associated utilities. Based on the learning experience of carrying out this major project, the following conclusions and recommendations are made.

- a) Modifying a transmission system primarily designed for supply of load to one that had to handle a very large export of power can challenge how one views a system. Standard terms of reference of how load flows through the system, the reliability issues around an islanded generator, and how to predict the effect of elements out of service all change.
- b) The use of computer modeling, engineering knowledge and EPC work processes can lead to an accurate electrical load for a plant.
- c) Adopting common electrical design philosophies that incorporate owner and standard industry practices can provide for a reliable electrical distribution system. Attention must be given to ensuring that all EPCs follow the standards and specifications consistently.
- d) It was fairly difficult relating the load flow studies that were independently conducted by the utility and the engineering contractor for the cogeneration plant. Each had its own terms of references and own standards on system modeling. More up front time should have been spent in defining the scope of the studies and determining the interface between the involved parties.
- e) A challenging aspect of the project was the project management of four EPC firms working simultaneously towards the same goal. It is recommended that a single engineering company be charged with coordinating the overall site power system protective relaying, control, indication, and annunciation philosophy.
- f) The Utility FMEA process for managing risks of work on energized substations and lines was very successful and would be followed again to manage risks.
- g) Being the first large generation project after deregulation had its own merits as some rules and requirements were not well defined at the time. These interface requirements were effectively developed by the in-house project team and the Alberta transmission grid authorities throughout this project.

- h) The responsibility of conducting a plant wide protective coordination study should have been assigned to one contractor rather than split to several contractors.
- i) A new intermediate role of the Industrial Owner was created because of the presence of the new cogeneration plant. The new role was one of a distribution utility taking power from a cogeneration plant and delivering of power to individual industrial plant customers within the Joffre site.
- j) The studies conducted for the cogeneration plant revealed that there is little value in islanding voluntarily to protect the generation from system disturbances.
- k) The selection of multi-pulse ASD concept has significantly reduced harmonics at source. The entire Joffre plant is in compliance with the utility harmonic requirements at 138 KV for voltage THD, current THD and IT product without the use of any harmonic filters.
- l) The IEEE 519-1992 standard was applied throughout the plant to determine that harmonics are within acceptable limits. The PCC for all new process plants was assumed at 13.8 kV.
- m) The method of cabling used for this project proved to be reliable and economical. The connection between the cogeneration project and the utility was made using 138 kV overhead transmission line. The main cabling within the plants was above ground on pipe racks.
- n) Common equipment standards and specifications and purchasing strategy lead to the selection of common equipment vendors and inherent cost savings.
- o) When embarking on a major project it is important to check exiting utility breaker ratings to determine if they are already over-dutied. In this case, it is the responsibility of the utility to upgrade their equipment.

X. REFERENCES

1. IEEE Standard 519 – 1992 "IEEE Recommended Practices and Requirements for Harmonic Control in Electric Power Systems".
2. Roy Billinton, Ronald N. Allan "Reliability Evaluation of Engineering Systems", Pitman Books Limited, 1983.
3. Roy Billinton, Ronald N. Allan "Reliability Evaluation of Power Systems", Plenum Press, 1984.
4. A. Paul Gabba, James D. Hill "Make Automatic Power Source Transfers a Success for Your Plant", IEEE PCIC #98-04.
5. Marty T. Cole, Joseph H. Kuczka, Vincent G. Rowe "North American Hazardous Locations: The Future", IEEE PCIC #96-01.

XI. ACKNOWLEDGEMENTS

The authors wish to acknowledge the contributions of Mr. Paul Kos of Power Systems Solutions for his contributions in the reliability section.

XII. VITA

Mr. John Dickin received his B.Sc. Degree in Electrical Engineering from the University of Calgary in 1974. He has worked in various industries including manufacturing, electric utility, refining and steel before joining the NOVA Chemicals Corporation in 1989 where he now provides project and engineering support. Mr. Dickin is a member of IEEE and the Association of Professional Engineers, Geologists and Geophysicists of Alberta. He presently is the Electrical Engineering Lead for the cogeneration project.

Dr. Robert Hanna received his B.Sc. Degree from the University Basra, Iraq in 1971. He obtained the M.Sc. Degree (with Distinction) from Queen Mary College, University of London, England in 1973 and Ph.D degree from Imperial College of Science and Technology, University of London, England in 1977, all in electrical engineering. Following a short teaching career, in 1981 he joined Gulf Canada, now Petro Canada as a central engineering specialist, providing technical support to the refineries in implementing capital projects and equipment selection. In 1995, he founded RPM Engineering Ltd., a certified consulting company in Ontario, Canada specializing in Adjustable Speed Drive applications, power quality studies and power system analysis. He has been an invited speaker to several utilities in Canada and has authored several IEEE/PCIC technical papers. Dr. Hanna is a senior member of IEEE, designated consulting engineer of the Association of Professional Engineers in Ontario and Fellow member of the Institution of Electrical Engineers, England. He is the Vice-Chairman of PCIC Conference to be held in Toronto, Canada in 2001.

Mr. Scott Randall received his B.Sc. degree in Electrical Engineering from Queen's University of Kingston, Ontario in 1983. He joined NOVA Chemicals Corporation in 1991 at their Sarnia, Ontario petrochemical facilities, providing project engineering and maintenance support. In 1997, Mr. Randall transferred to NOVA Chemicals' Joffre, Alberta site where he is involved in project management within the Joffre 2000 expansion projects. These projects include the construction of a world class ethylene facility, a polyethylene facility, a Cogeneration plant and their associated utilities. He has co-authored one other IEEE/PCIC technical paper. Mr. Randall is a member of IEEE and the Association of Professional Engineers in Ontario.

Mr. Chris Dedeurwaerder received his B.Sc. in Electrical Engineering from the University of Alberta, Edmonton in 1998. He joined Nova Chemicals Corporation in 1998 at their Joffre, Alberta petrochemical facilities. Chris was involved in providing electrical engineering support for the Joffre 2000 expansion projects. These projects include the construction of a world class ethylene facility, a polyethylene facility, a Cogeneration plant and their associated utilities. Mr. Dedeurwaerder is a member of IEEE and the Association of Professional Engineers, Geologists and Geophysicists of Alberta.