

Minimizing Plant Interruption Caused by Line Disturbances Using Active Voltage Conditioners

IEEE Canada – Webinar Presentation
May 21, 2008

Bob Hanna, FIEEE, P.Eng.
RPM Engineering Ltd.
www.rpm-eng.com

David Ezer, MIEEE
Omni Power
www.omniverter.com

www.ieee.ca

Presentation Overview

- **Power Quality Issues**
- **Impact of Power Quality**
- **Voltage Sag**
- **Equipment Tolerances**
- **Field Measurements**
- **Mitigation Techniques**
- **Case Studies**
- **Conclusions**

Power Quality Issues

- **Power Quality Per IEEE Std 1100-2005 (Emerald Book) is “the concept of powering and grounding electronic Equipment in a manner that is suitable to the operation of that Equipment and compatible with the premise wiring system and Other connected Equipment”**
- **Power Quality problems are of increasing concerns in industry and commercial installations**
- **Modern Equipment is more sensitive to Voltage Sags**

Equipment Impacted by Power Quality

- **Industrial Power Electronic Equipment including Adjustable Speed Drives, UPS, Soft Starter, etc.**
- **Data Control Centres**
- **Electronic Process Monitoring and Control, such as PLC**
- **Telecommunications**
- **Robotics**

What is the Primary Problem ?

- ***Voltage Sags*** have been identified as being the **Single Most Expensive Power Quality Event**
- **Both Industrial and Commercial Facilities are affected by this type of problem**
- **In many cases, the customer believes that the incoming supply has been interrupted i.e. a complete loss of power, when in fact it was a severe voltage sag**
- **Voltage Sags are fact of life and can not readily be eliminated from regular Utility System**

What is a Voltage Sag (Dip)?

- A Voltage Sag, Per IEEE Std 1159-1995, is:
“ A decrease in rms Voltage at the power frequency for durations from ½ cycle to 1 min, *reported as the Remaining Voltage*”
- Voltage Sag is a sudden Voltage drop while the Load remain connected to the Supply. Or it is a temporary reduction of the Voltage below a user specified threshold
- Sag is characterized by its magnitude and duration. Magnitude range from 10%-90% of nominal Voltage. Typical duration is ≤ 1 Sec

What is a Voltage Sag (Dip)?

- The measurement of Voltage Sag is stated as a **percentage of the Nominal Voltage**. It is a measurement of the **remaining Voltage** and is stated as a sag **TO** a Percentage value. Thus a Voltage Sag to 70% is equivalent to 70% of Nominal Voltage, or 336 V for a 480 V system
- An interruption, on the other hand, is the reduction of supply voltage to less than 10% of the Nominal rms magnitude.
Example: Supply Voltage is reduced to less than 48V on a 480 V System

Cost Of Power Quality

- **US Estimates of industrial cost is multi-billion \$ per annum**
- **EPRI reported that 97% of cost related to Power Quality is due to voltage Sags.**
- **Lost Production, Wasted Product, Possible Equipment Damage, Restart Time and Associated Labour**

Per IEEE Std. 1100-2005, Emerald Book & EPRI Study

Number of Sags per Year

Normal

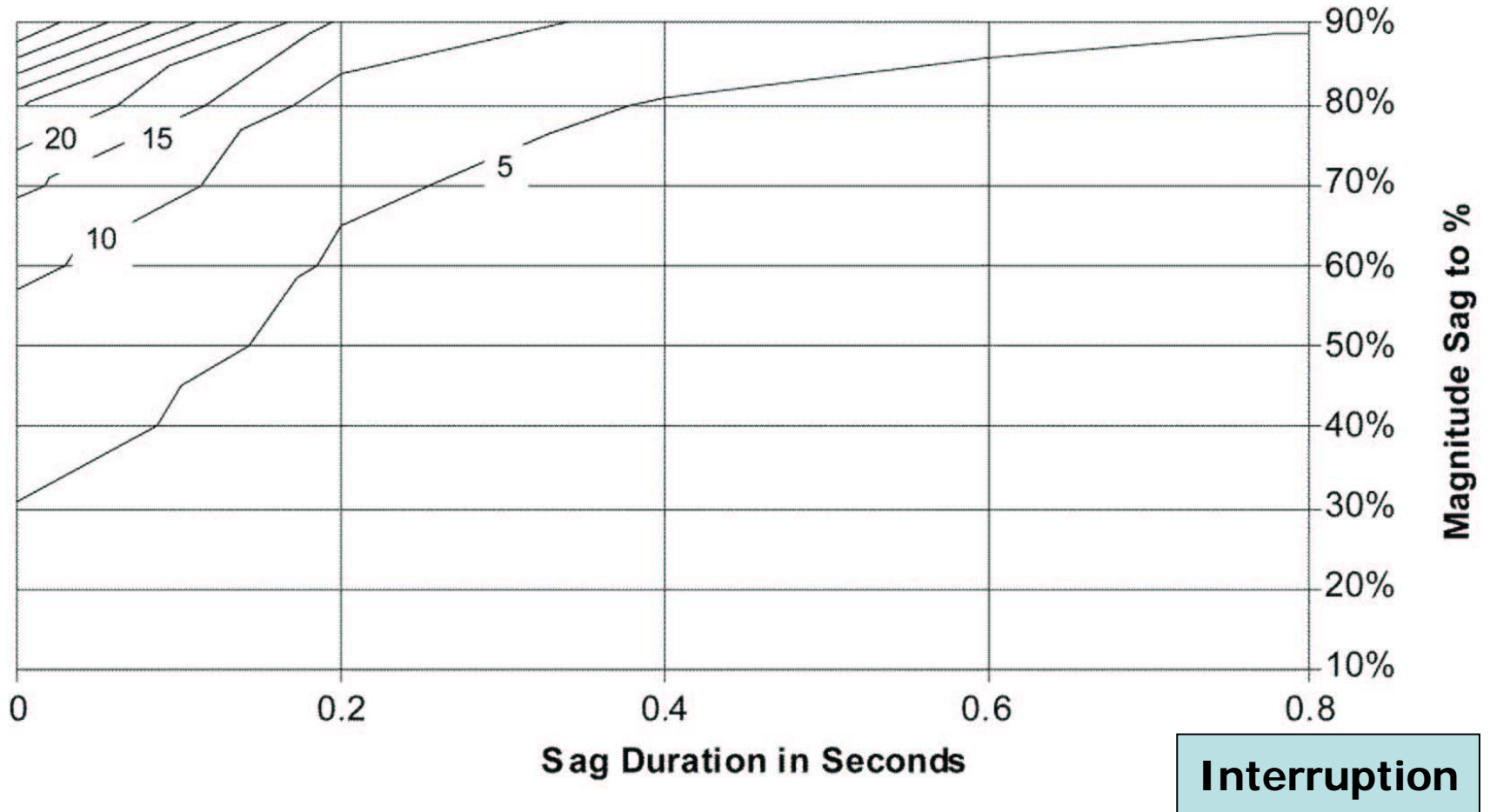

Magnitude Sag to %

Sag Duration in Seconds

Interruption

New ITI (CBEMA) Curve

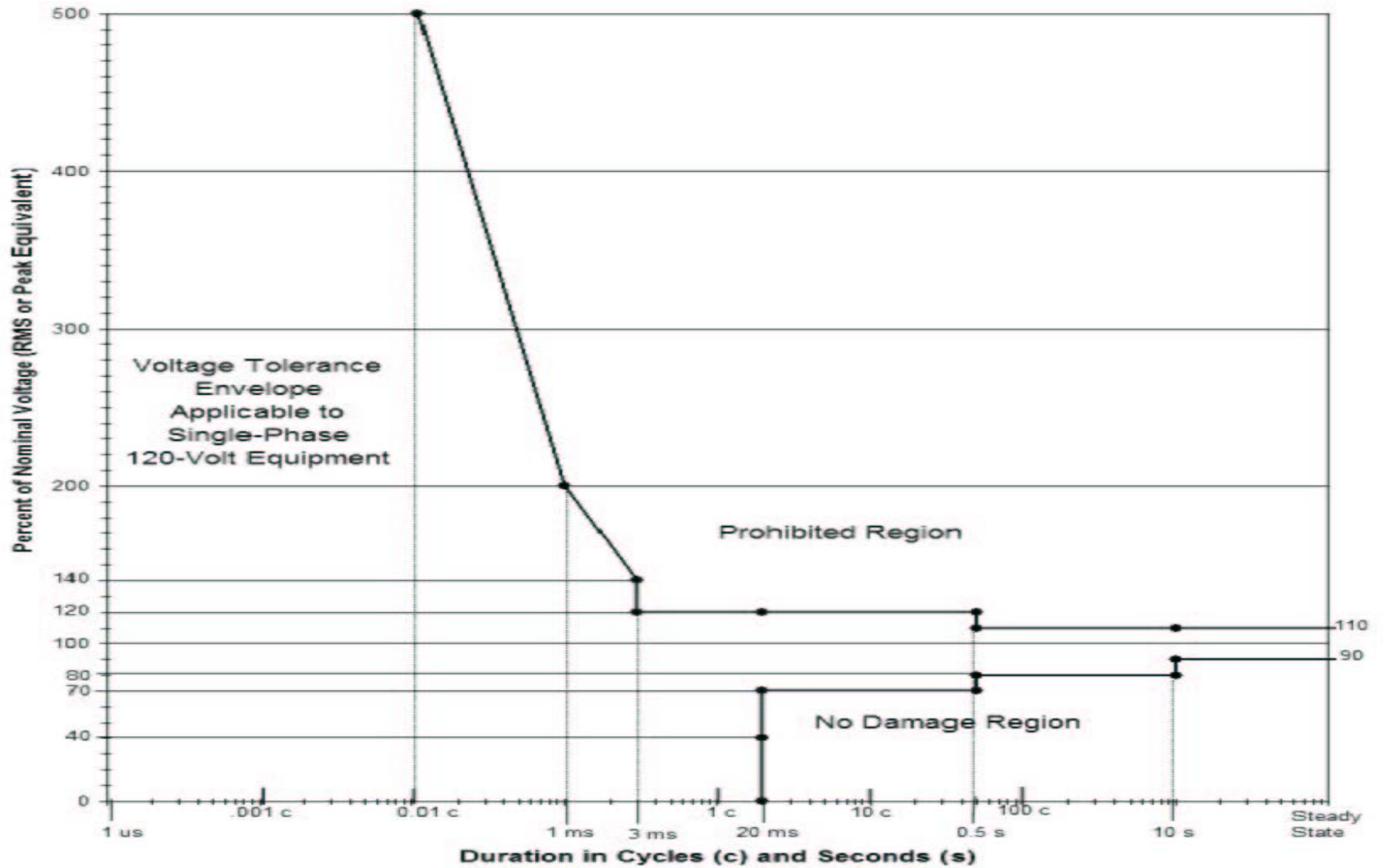

Accident Happens !



Birds Nest



© Ralph Underwood

Electrical Dist. System – Spaghetti Design



Causes of Voltage Sags

- **External (Utility System)**
 - Bad Weather
 - Equipment Failure
 - Human Error,
 - Animals & Birds,
 - Vehicle, etc.
- **Internal (Industrial Plant):**
 - Electrical fault,
 - Motor Starting,
 - Switching, etc.

Isolated Redundant UPS configuration

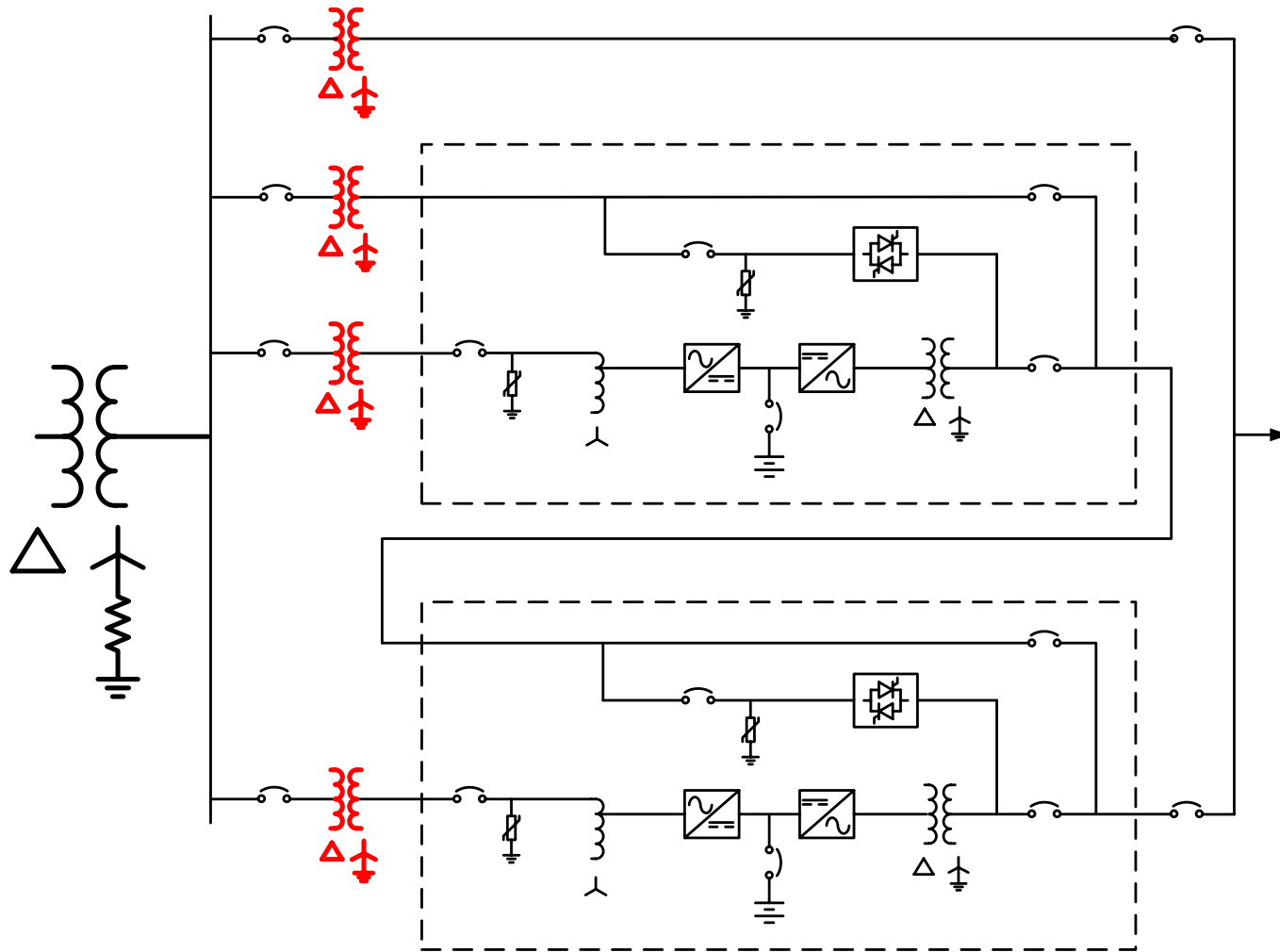

Voltage Sag TO 50% for 4 Cycles- UPS System Crashed due to Bad Battery Cell in each of the four strings. Disturbance caused by a fault on 230 KV line

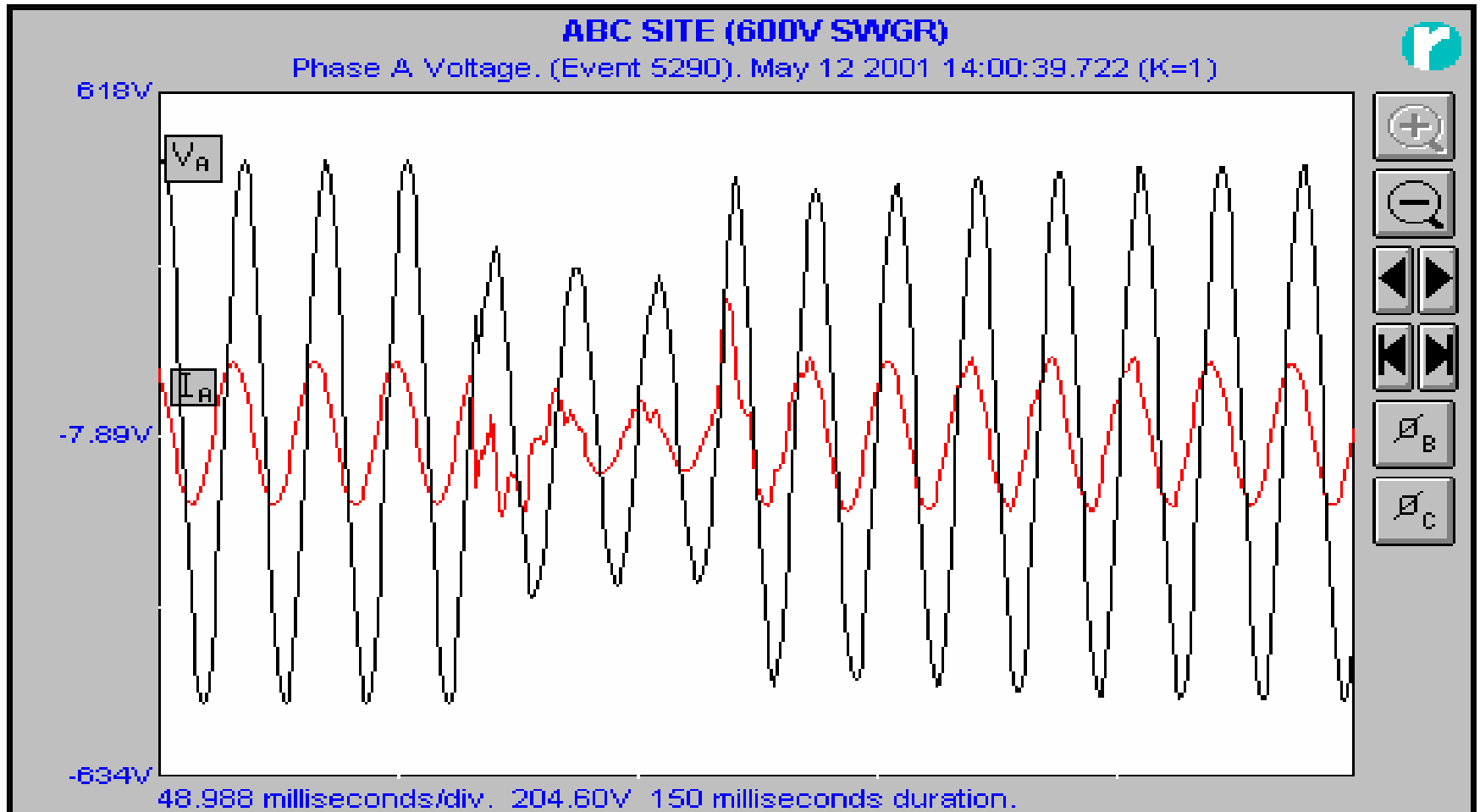

UPS Alarm History

0123 05/12/01 14:00:09.11.1 sbs on

0124 05/12/01 14:00:09.11.1 inverter off

0125 05/12/01 14:00:09.10.2 dc low shutdown

0126 05/12/01 14:00:09.10.2 dc voltage low

0127 05/12/01 14:00:09.10.1 input voltage normal

0128 05/12/01 14:00:09.09.2 battery voltage low

0129 05/12/01 14:00:09.08.1 input voltage low

Voltage Sag TO 65% for 100 ms

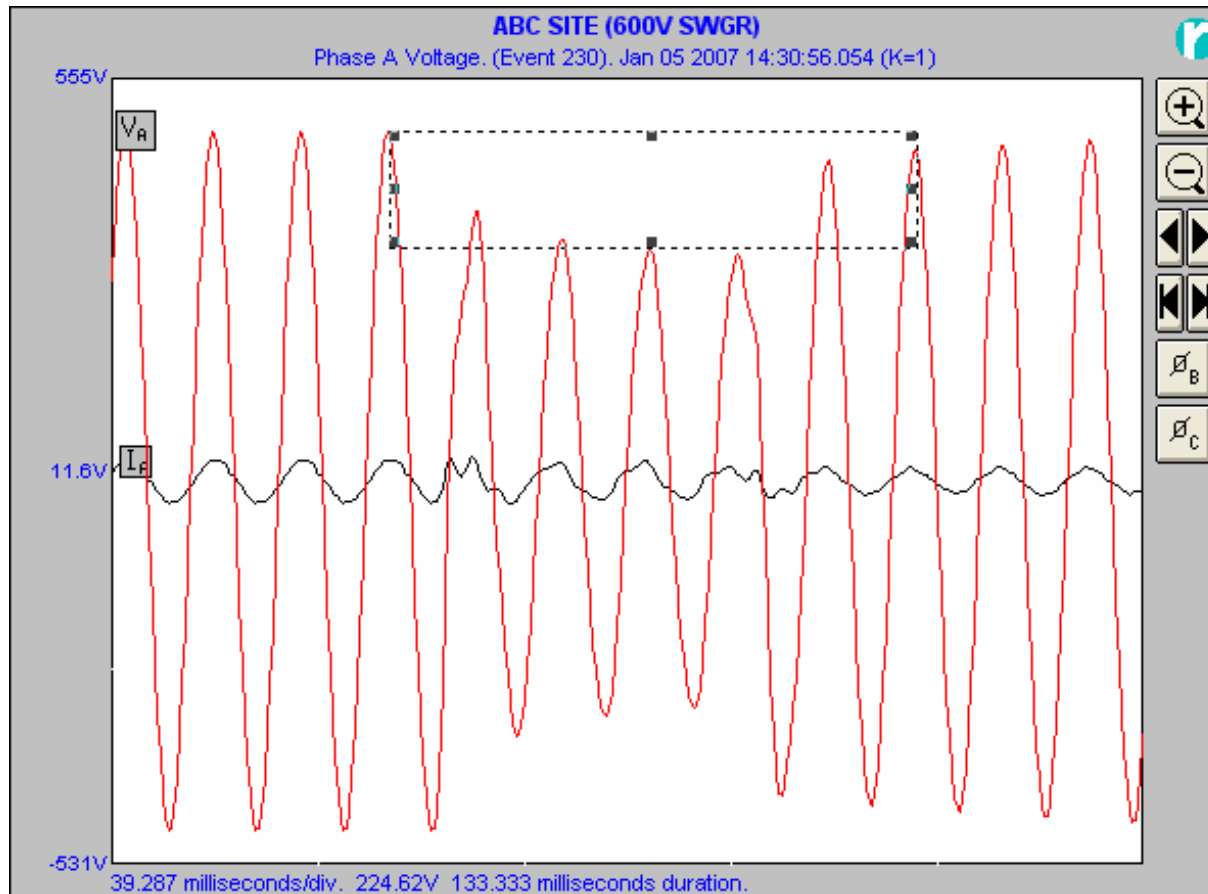

Time: 100.7 ms; Min: 318.0V; Max: 481.7V; Pk-pk: 163.7V

UPS Alarm History

0051 01/05/07 14:30:24.06.4 UPS summary alarm
0052 01/05/07 14:30:23.59.3 sbs bypass frequency normal
0053 01/05/07 14:30:23.46.3 rct in current limit
0054 01/05/07 14:30:23.45.3 rct in recharge
0055 01/05/07 14:30:23.38.3 sbs bypass voltage normal
0056 01/05/07 14:30:23.37.3 input voltage normal
0057 01/05/07 14:30:23.36.3 sbs bypass voltage low

0058 01/05/07 14:30:23.34.4 input voltage low

Two Voltage Sags To 50% within 1 Sec.

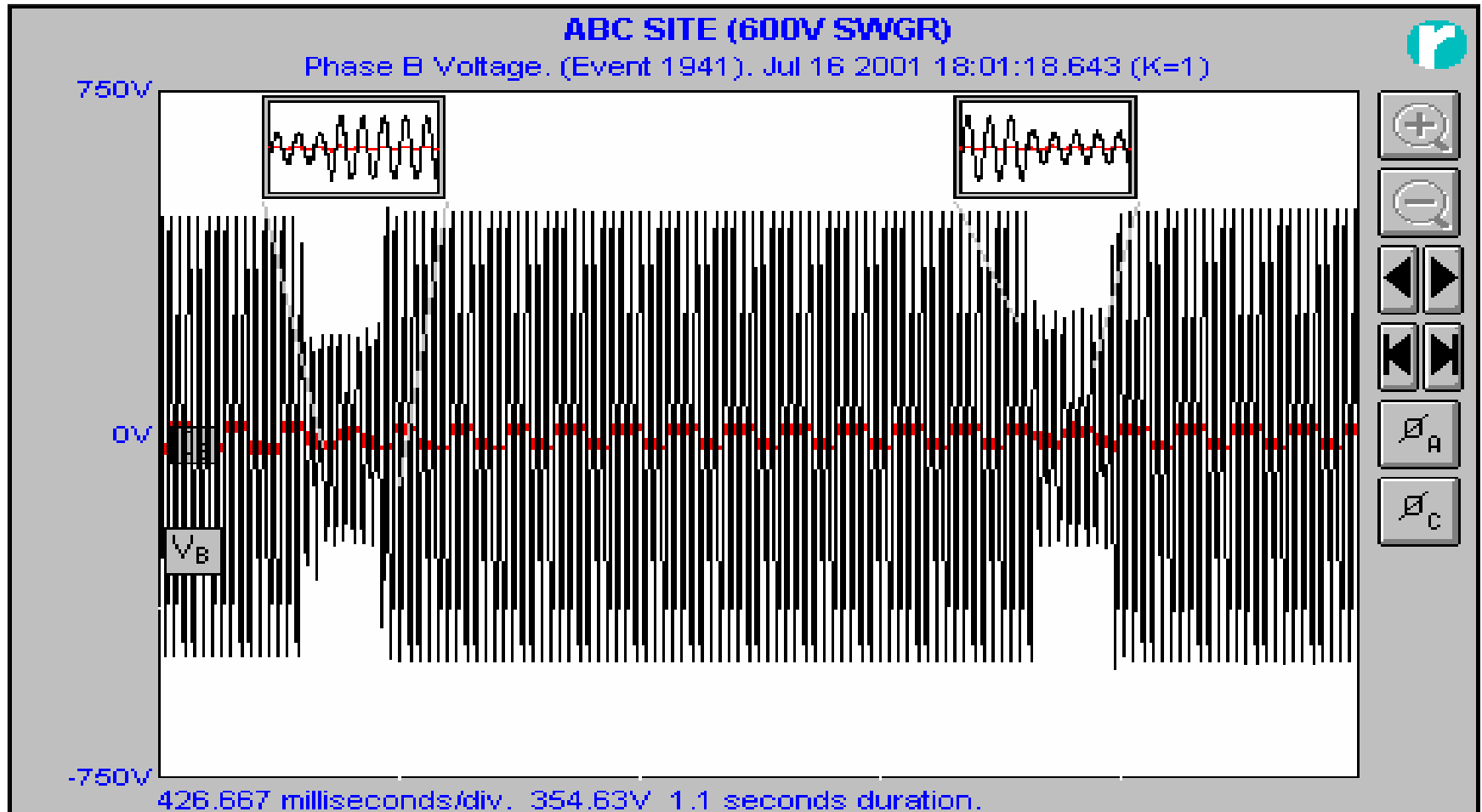

Summary of Voltage Sags for a Data Processing Centre for the period Jan – Dec, 2007. The Incoming Supply is at 27.6 KV. Twenty Three Disturbances Captured

Date	Time	Sag Magnitude To % Nominal	Duration	Comment
January 05	14:31	65%	101 ms	Severe Disturbance
January 24	11:50	75%	168 ms	Severe Disturbance
January 24	11:50	75%	168 ms	Severe Disturbance
January 30	06:24	45%	265 ms	Severe Disturbance
January 30	13:34	63%	168 ms	Severe Disturbance
January 30	13:34	63%	168 ms	Severe Disturbance
February 27	11:55	80%	83 ms	Severe Disturbance
March 07	03:01	60%	100 ms	Severe Disturbance
March 11	12:08	65%	116 ms	Severe Disturbance
March 17	10:42	40%	150 ms	Severe Disturbance
March 17	10:42	40%	150 ms	Severe Disturbance

Summary of Voltage Sags for a Data Processing Centre for the period Jan – Dec, 2007. The Incoming Supply is at 27.6 KV. Twenty Three Disturbances Captured

Date	Time	Sag Magnitude To % Nominal	Duration	Comment
May 18	09:03	45%	50 ms	Severe Disturbance
May 24	13:16	35%	50 ms	Severe Disturbance
May 31	16:29	35%	132 ms	Severe Disturbance
June 11	16:16	0%	832 ms	Momentary Power Outage (Auto Re-closure)
June 19	15:16	0%	1 minutes	Prolonged Power Outage Emergency Gen. started
July 04	07:28	70%	168 ms	Severe Disturbance
August 20	01:19	60%	116 ms	Severe Disturbance
September 26	01:42	58%	51 ms	Severe Disturbance
November 25	07:06	0%	823 ms	Momentary Power Outage (Auto Re-closure)
November 25	13:17	0%	68 ms	Power Outage Phase B only
December 16	02:22	71%	150 ms	Severe Disturbance
December 16	02:25	71%	150 ms	Severe Disturbance

Momentary Loss of Power - 830 ms. (Auto Re-closure)

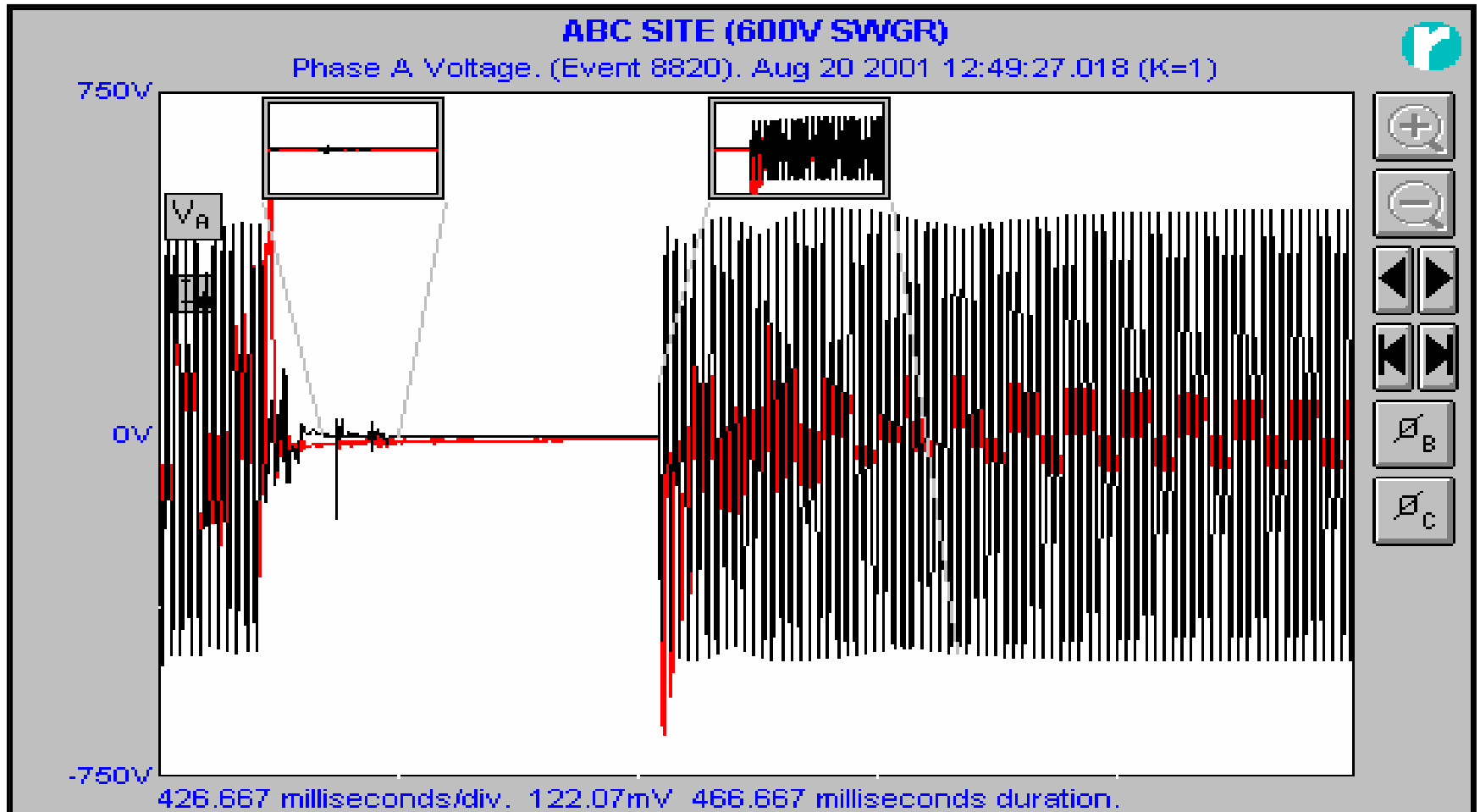

Total Interruption Generator on line in 4 sec.

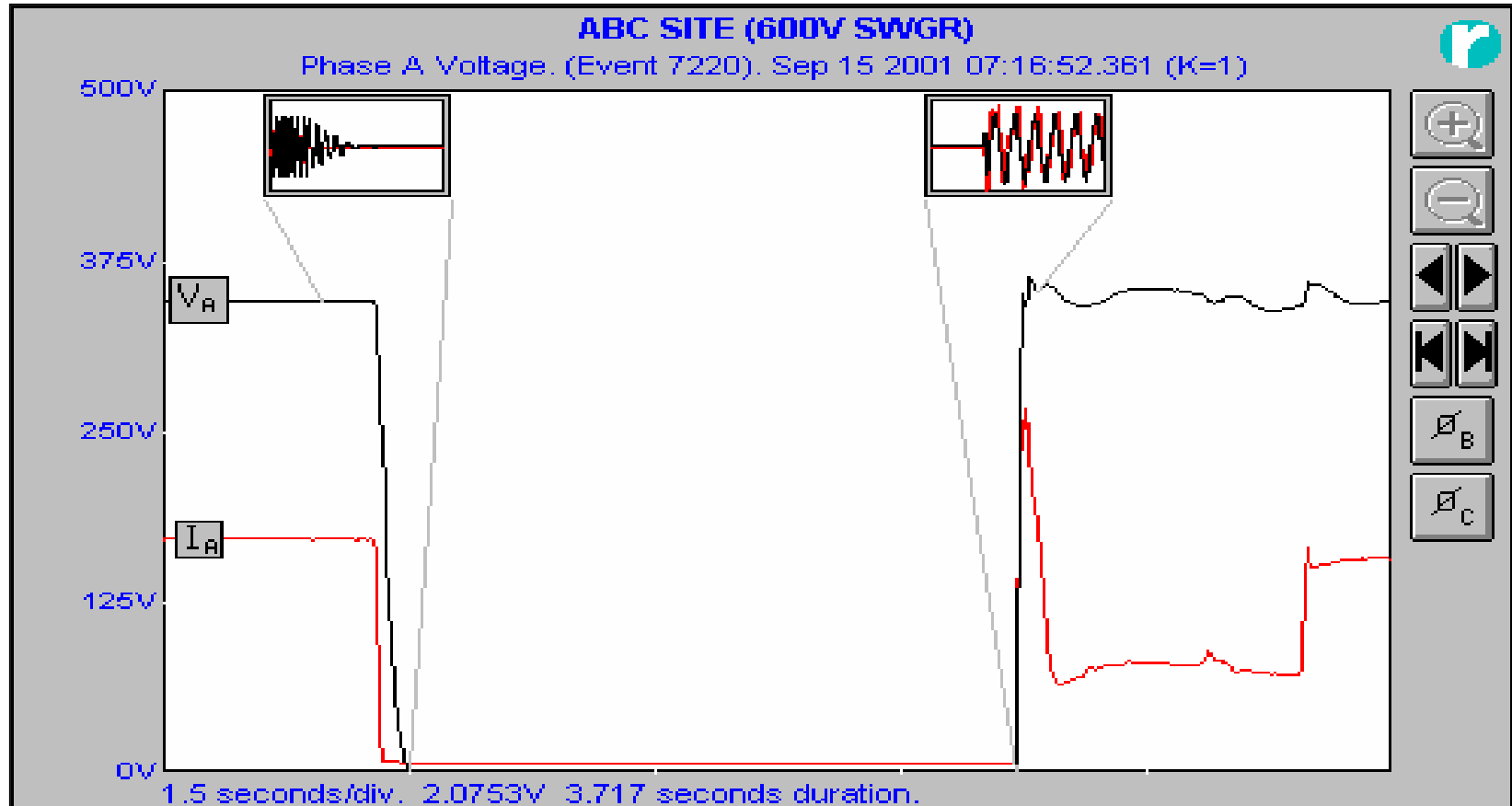

Mitigation Techniques

- **Uninterruptible Power Supply (UPS)**
- **Tap changers**
- **Constant Voltage Transformers (CVT)**
- **Active Voltage Conditioners (AVC)**

Uninterruptible Power Supply (UPS)

- **Generally intended for small and computer loads.**
- **Rely on quality of the battery**
- **Impractical for large industrial loads**
- **Maintenance**
- **Air conditioned space**

Constant Voltage Transformers (CVT)

- **Inefficient – run hot**
- **Intended for single phase loads and small 3-phase loads**
- **Potentially resonant with loads and in some case causing damage**

Tap Changers

- **Slow and inefficient**
- **Potentially resonate with the load**
- **Step changes in voltage**
- **Good for steady state change in voltage**

Active Voltage Conditioners (AVC) Concept

- The AVC consists of an inverter which feeds an injection transformer connected in series with the utility supply.
- The inverter produces compensating voltage vectors which correct for utility voltage disturbances (sags, imbalance, flicker, voltage harmonics and overvoltages, etc).
- The AVC draws its power from the input supply via the rectifier when called upon to provide correction.
 - There are NO storage devices in the basic AVC
 - NO back feed of any upstream fault

Active Voltage Conditioner

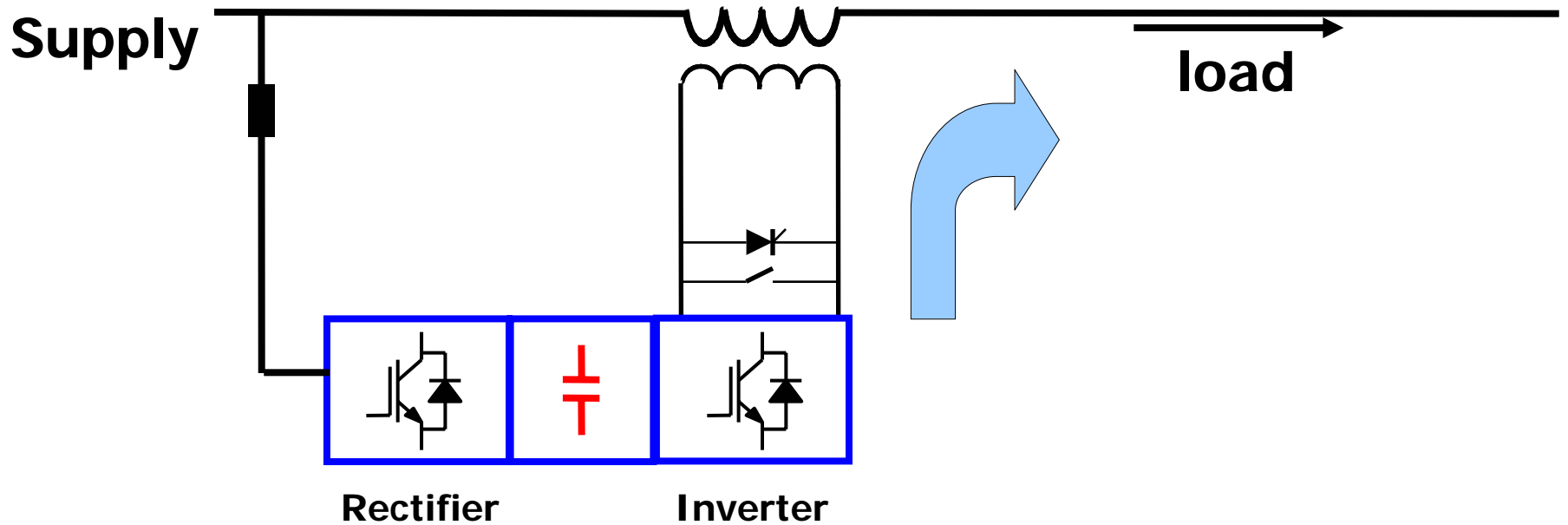

Key Features

- Provides rated % protection for 30 Seconds
- It is an On Line device so no switching threshold
- Fast response $< \frac{1}{4}$ ms to initiate correction
- Complete correction to $\pm 1\%$ in 6 ms ($< 1/2$ cycle)
- Continuously variable control (no step changes in output)
- Very efficient (typically $> 98.5\%$)
- High speed microprocessor controlled solution
- Continuous $+/-10\%$ voltage correction

Inverter controlled power conditioning for high power applications

AVC Ratings

**25 kVA to 5 MVA
(Low Voltage 208V-600V)**



**1 MVA to 50 MVA
(Medium Voltage 2-36kV)**



3- phase symmetrical sags – AVC Response

Ref.	Sag/Swell	AVC Output (L-L)
A	109%, 109%, 109%	100%, 100%, 100%
B	68%, 69%, 69%	99%, 99%, 100%
C	49%, 50%, 49%	80%, 81%, 81%

AVC Output Voltage
(Line to Line)

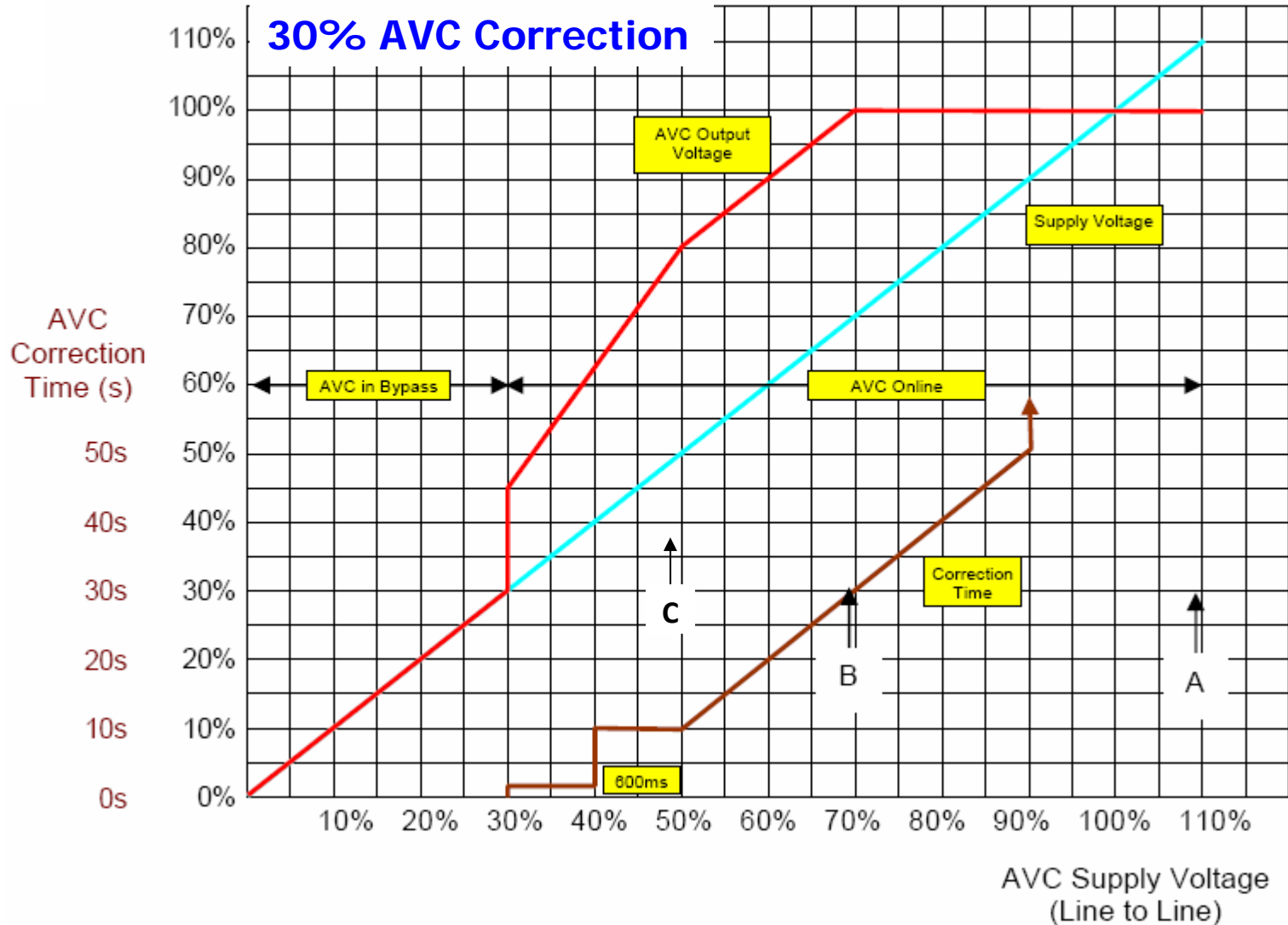

1- ph. Unbalanced sags – AVC Response

Ref.	Sag/Swell	AVC Output (L-L)
A	80%, 100%, 100%	100%, 100%, 100%
B	49%, 100%, 100%	97%, 99%, 99%
C	39%, 100%, 100%	93%, 98%, 98%

AVC Output Voltage
(Line to Line)

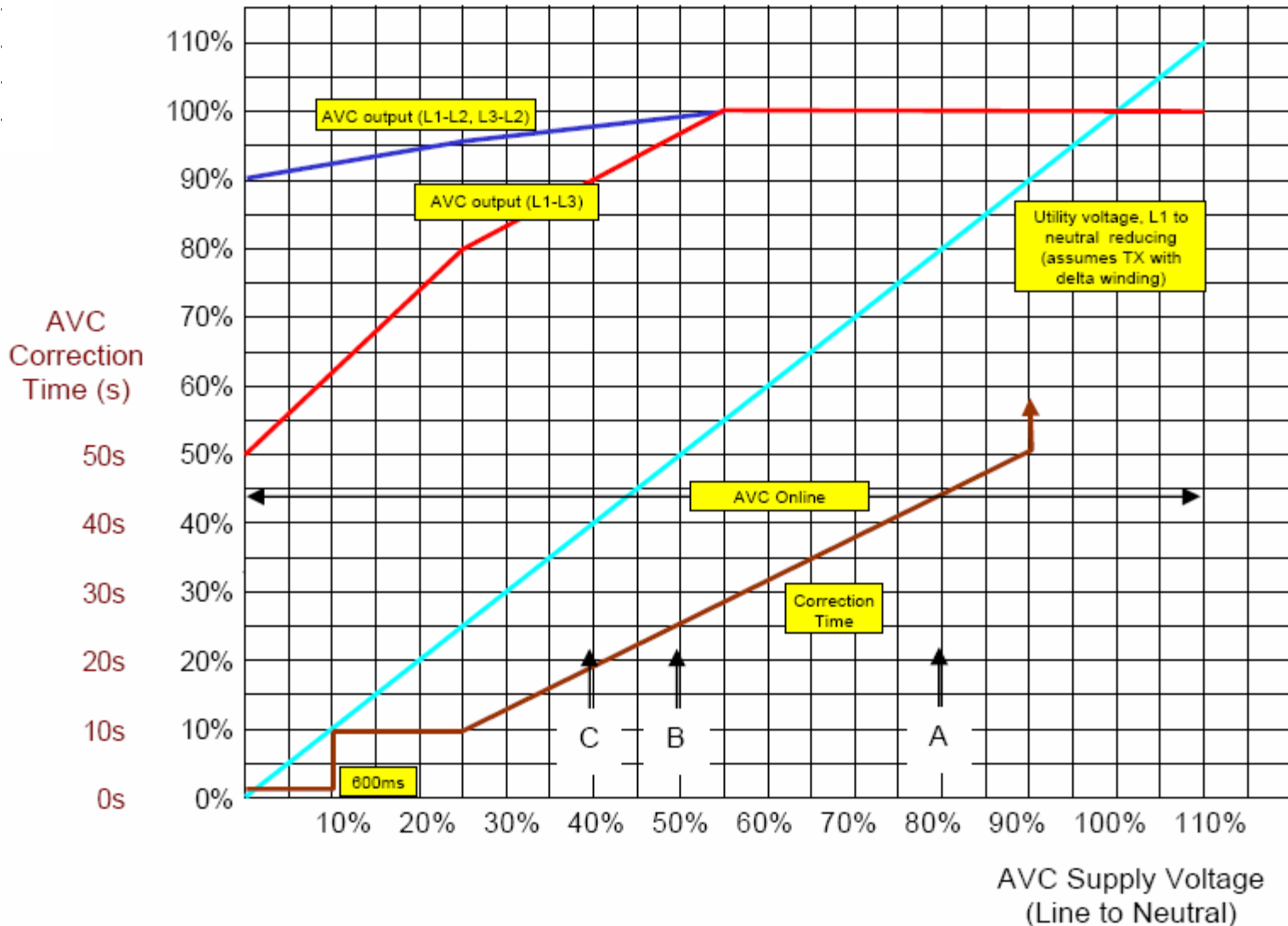

EPRI Factory Test For 208 V, 3-Ph 70% Sag

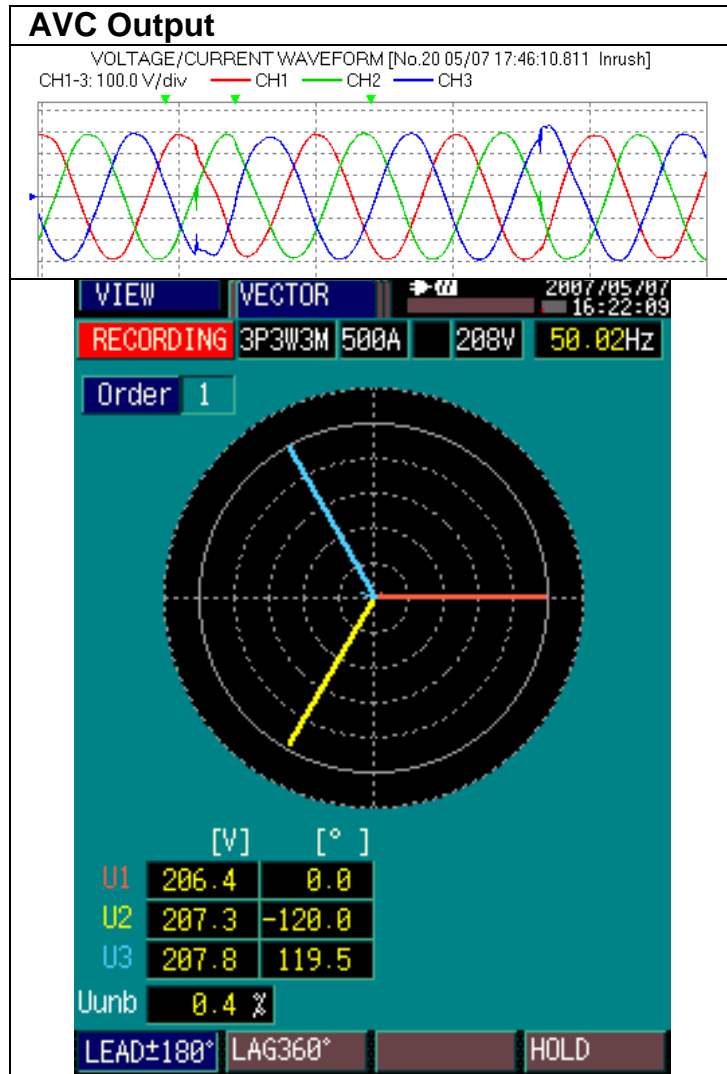
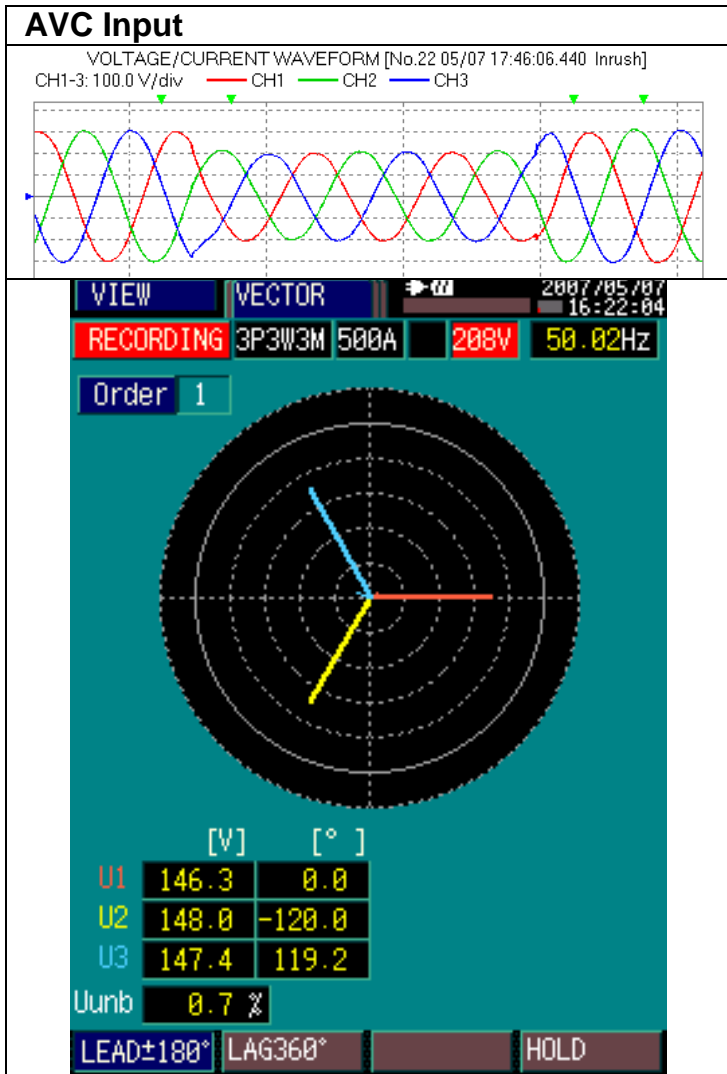
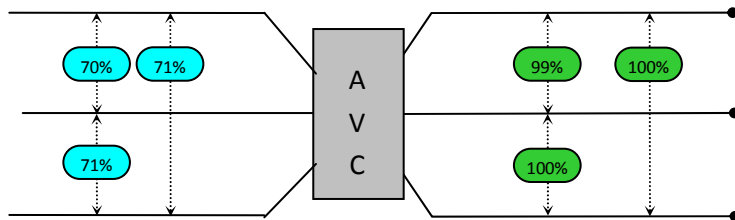

EPRI Tests L-G, 40% Sag on 480V system

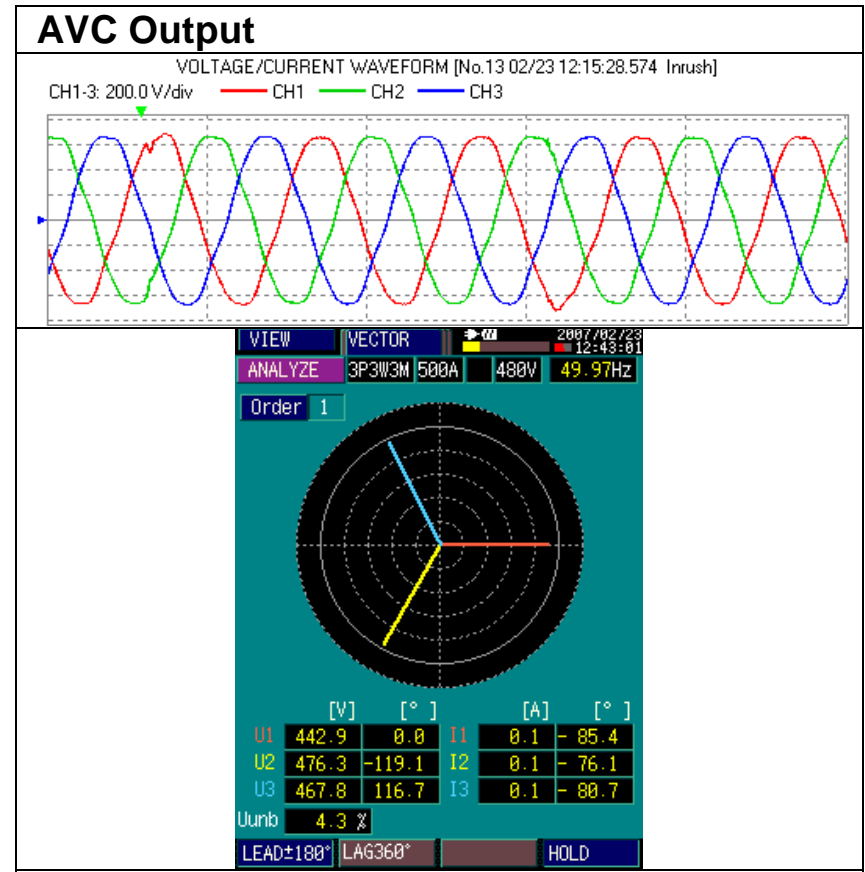
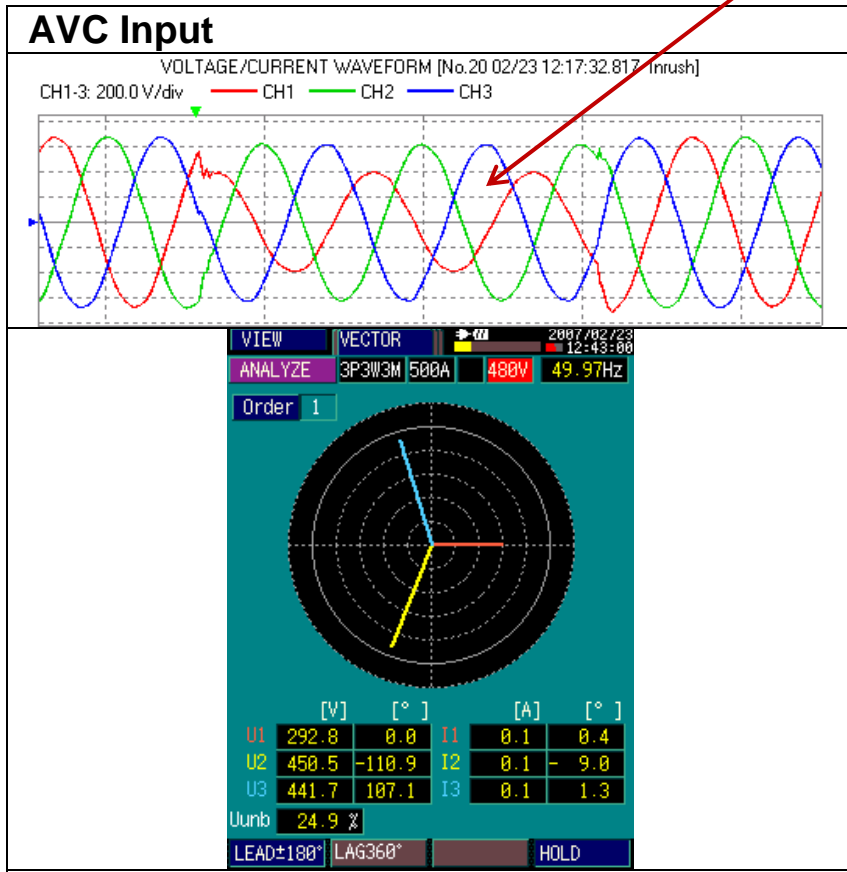
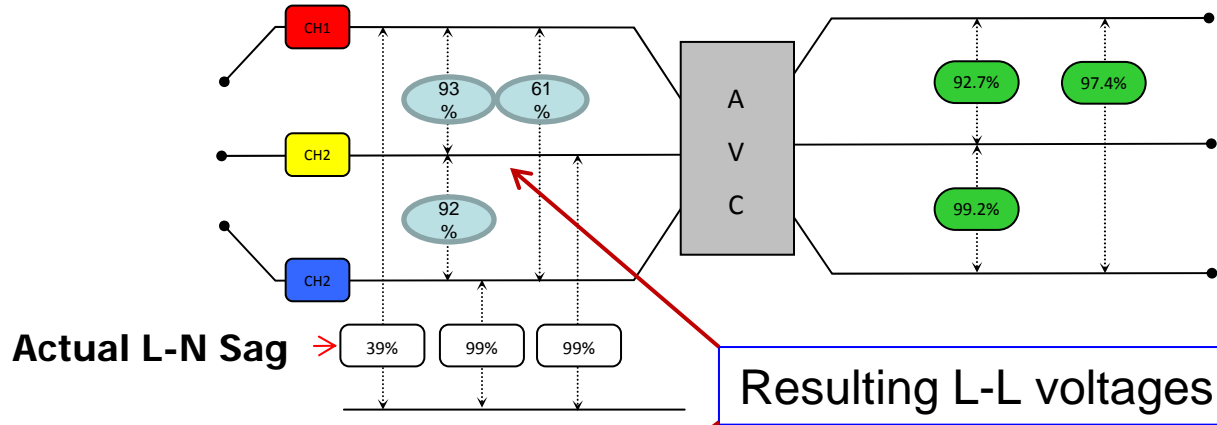

AVC Store – Power Outage protection

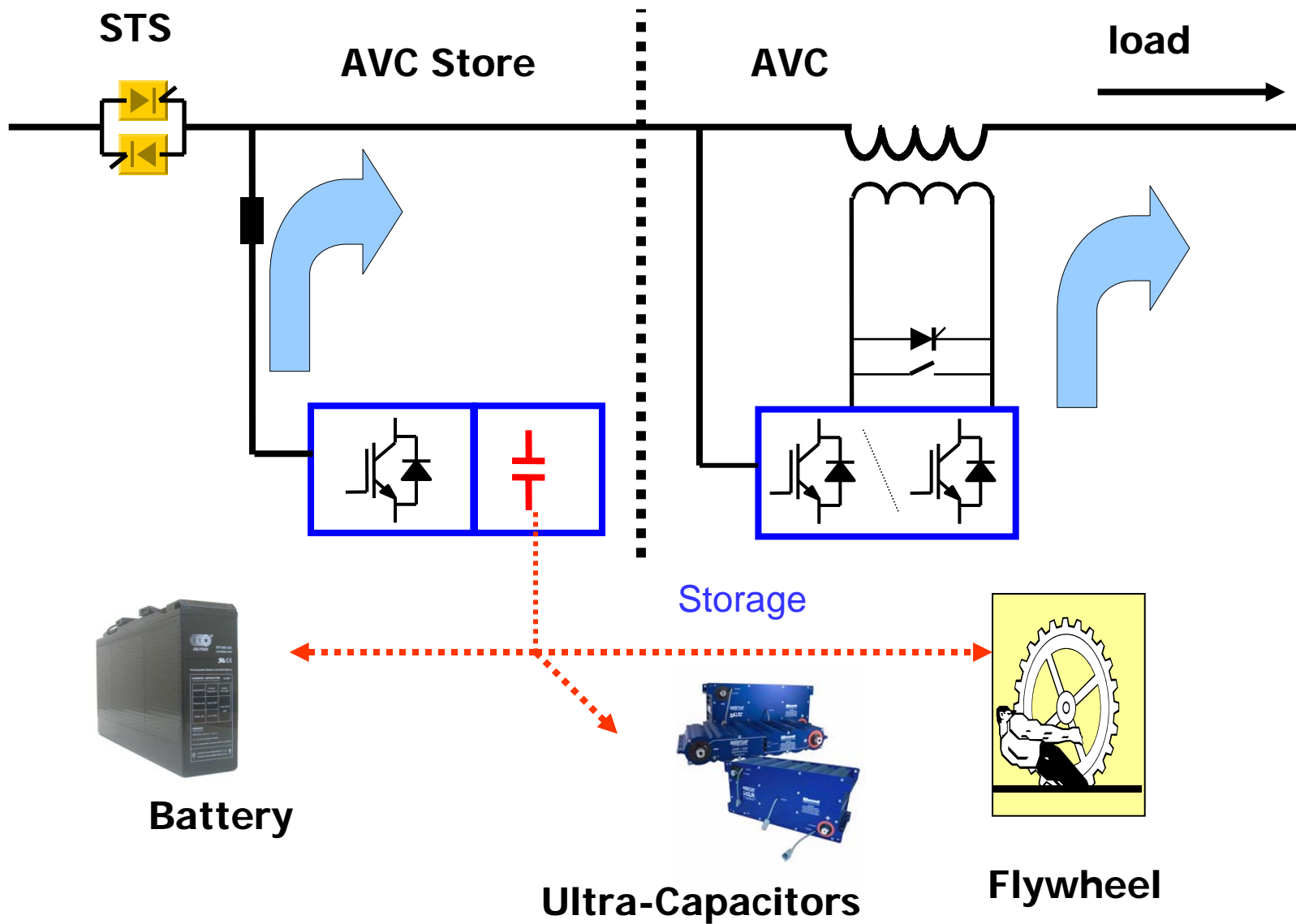

Upgrade from STD to AVC Store

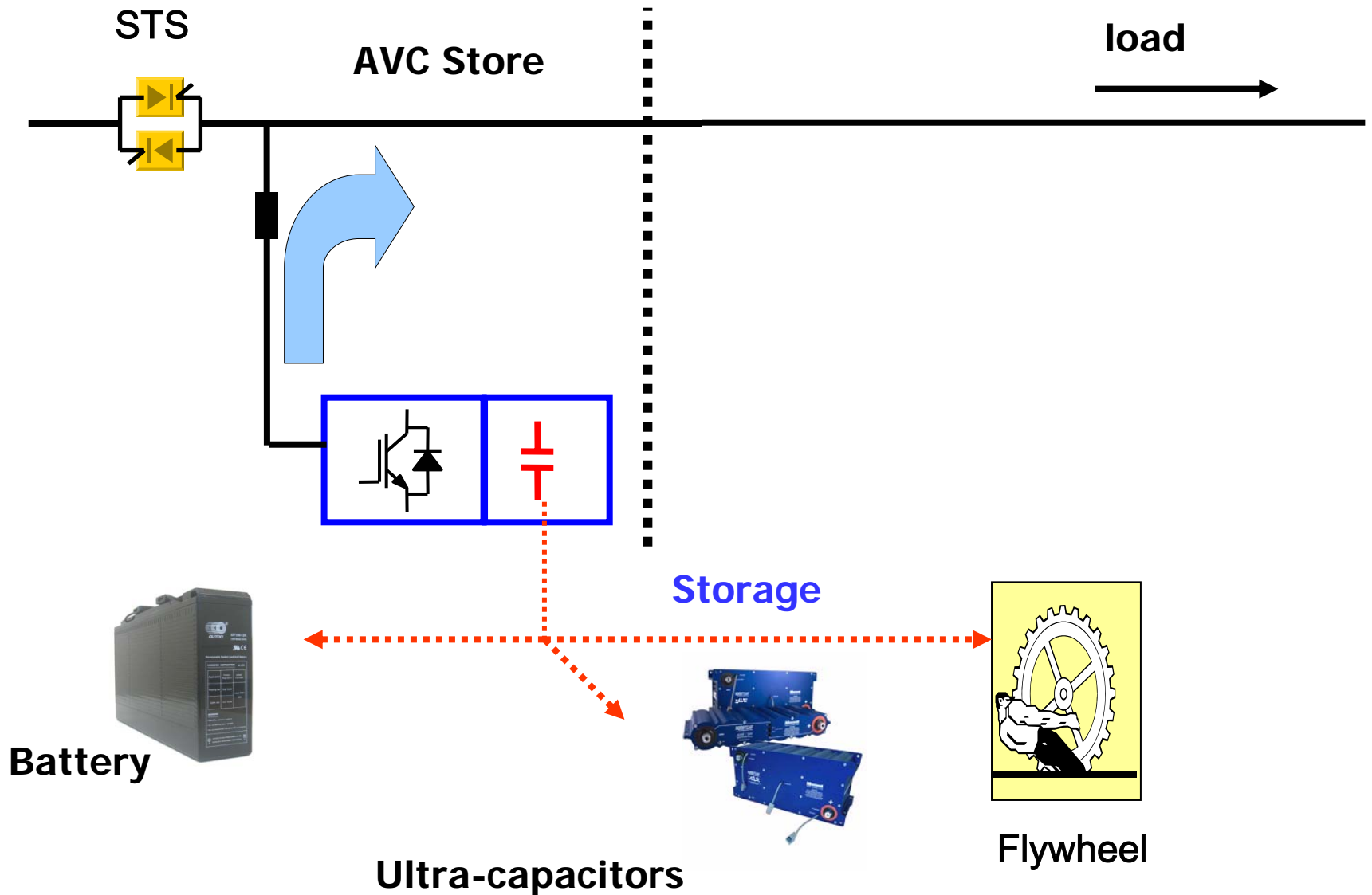

AVC front panel - Run

Status

Event log

Product

Menu

Summary

0

Status: RUN

Input

V1= 381 V

V2= 383 V

V3= 383 V

Frequency

60.0 Hz

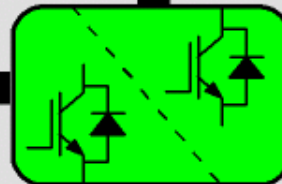
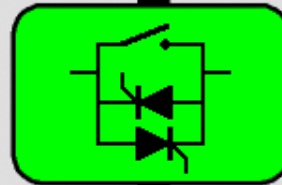
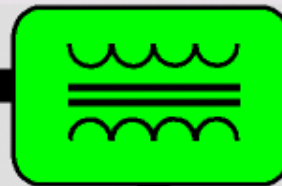

Output

V1= 479 V

V2= 479 V

V3= 480 V

I1= 47 %

I2= 48 %

I3= 45 %

AVC front panel - Events

Status

Event log

Product

Menu

Summary

0

Status: RUN

Date	Time	Type	Origin	Description
2007-06-20	14:53:11.70	Sag end		
Running , 820 ms, 84%, 74%, 79%, 99%, 99%, 100%				
2007-06-20	14:53:10.87	Sag start		
Running				
2007-06-20	14:53:07.33	Sag end		
Running , 750 ms, 89%, 90%, 100%, 99%, 99%, 99%				
2007-06-20	14:53:06.58	Sag start		
Running				
2007-06-20	14:52:46.37	Start Local	System	

AVC front panel - Features

Navigation buttons: Status, Event log, Product, Menu, Summary. A red button with a black 'O' is also present.

Status: RUN

Customer:	
Plant :	
Site :	

2007-06-28 14:29:55

Run time :	1000 Hour
On time :	1000 Hour

Active Voltage Conditioner	
Model :	AVC2S 30%
Power :	1200 KVA
Voltage :	480 V
Release :	R1B1
Serial Number :	20000314

DHCP :	false
IP addr :	192.168.0.44
IP mask :	255.255.255.0
Gateway :	192.168.0.253
Eth.MAC :	44:4d:50:62:1a:aa

IP Addressable
MODBUS TCP

AVC Maintenance

LCD touch screen
c/w diagnostics



Modular design



Modules in cabinets



Use of AVC in conjunction with UPS

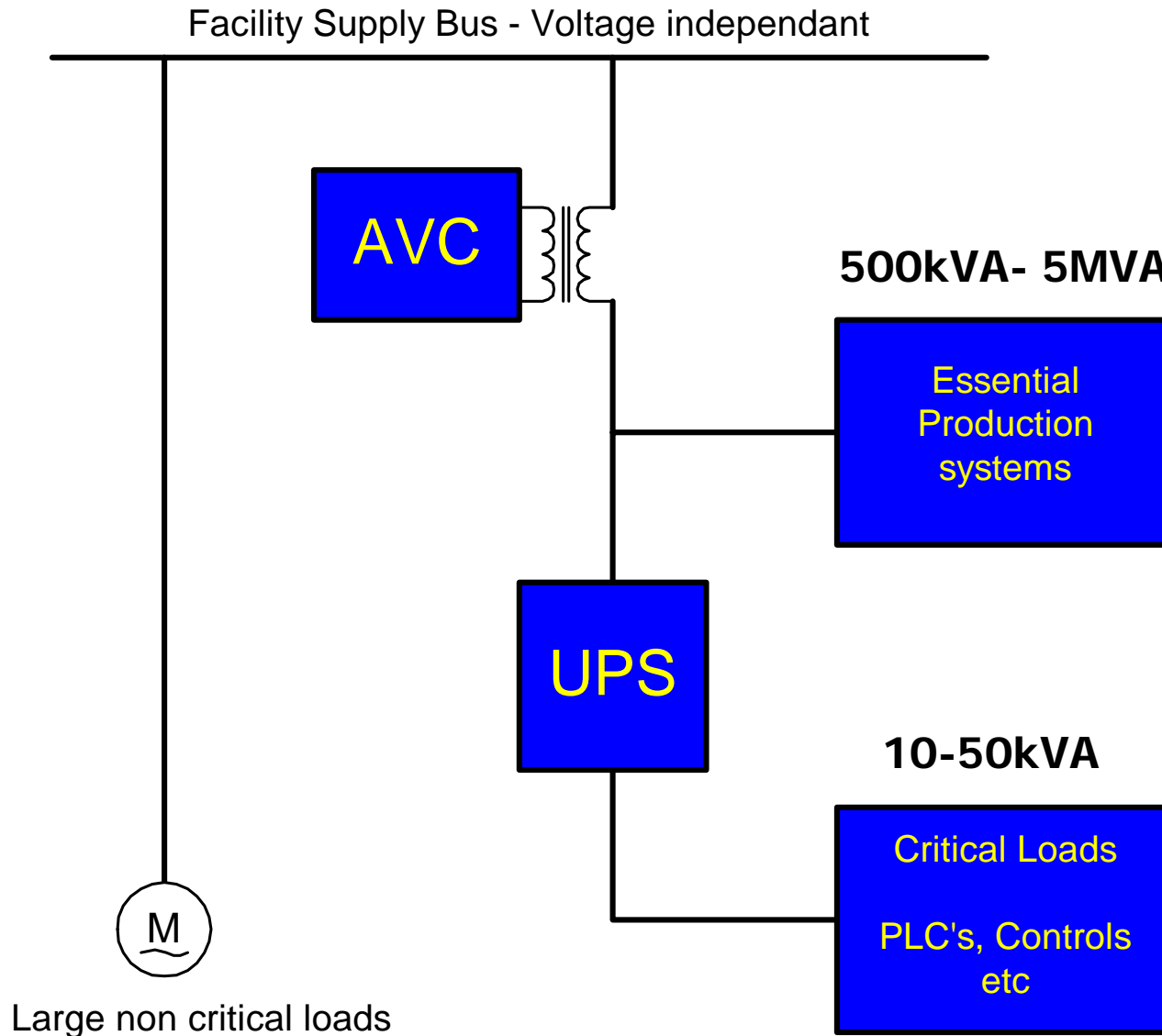

AVC Installed Base

North America

- Over 400 units
- 12 MVA largest site
- 26kV highest voltage
- Average unit size
800kVA

Worldwide

- 1700 units installed
- 192 MVA largest site
- 11kV highest voltage
- Average unit size
1.2MVA

AVC Capabilities - Performance

- **Deep Sag correction for 30 seconds**
- **Up to 30 seconds of total outage protection (AVC Store)**
- **Fast response 1/8 cycle (2 ms)**
- **Continuous Voltage regulation 90-110%**
- **Voltage balancing**
- **Flicker reduction**
- **Voltage Harmonic improvement**

Capabilities – Design Ratings

- **Wide range up to MW systems**
- **Configurable to site specific power problems**
- **Low source impedance – High inrush loads, i.e. Motors, MRI's etc**
- **NEMA 1 std, NEMA 4 Optional**
- **No HVAC required (except for storage devices)**

Case 1 -High Speed Bottling Plant (Alcohol)

- **Incoming supply: 27kV**
- **On Average, 30 events per year**
- **Penalties and damages along with lost production**
- **Over 10,000 drives and sensors**

Solution – High Speed Bottling Plant

- **Installed a 27kV AVC - 2003**
- **2,000 kVA AVC, Outdoor Unit – 30% rated**
- **Site wide solution due to the number of loads that needed to be protected.**
- **Installed at incoming switchgear**

Field Measurements – Case 1

AVC
Input
Voltage

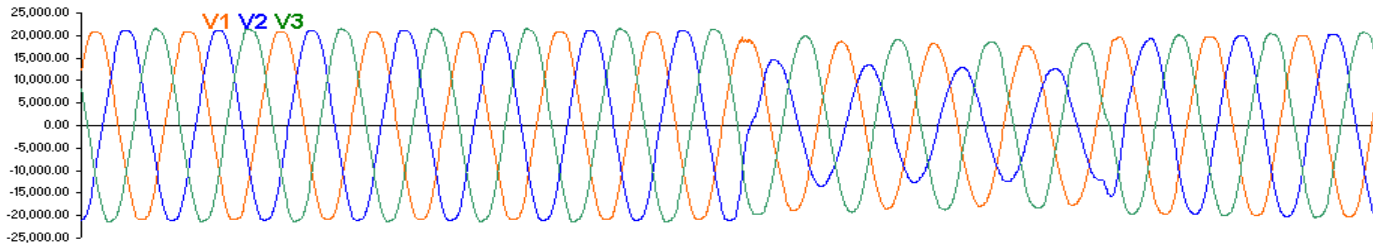

L-N Volt
V1=82 %
V2=58 %
V3=87 %

AVC
Output
Voltage

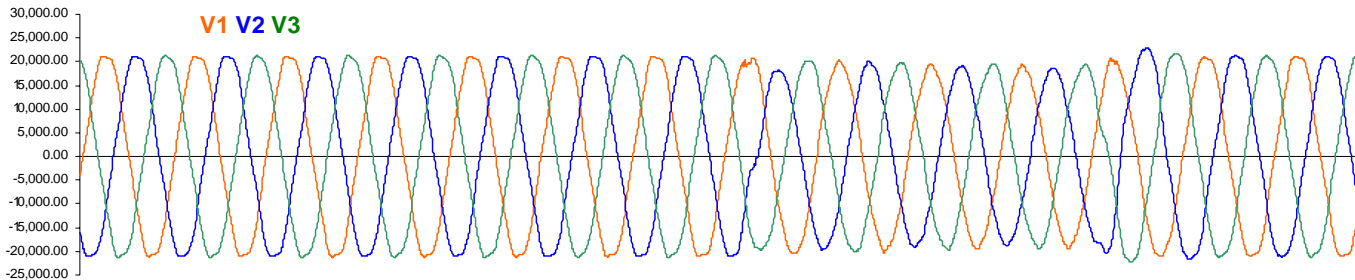

L-N Volt
V1=97 %
V2=98 %
V3=97 %

Can correct the voltage sags close to your critical equipment and prevent unplanned stoppages

Field Measurements – Case 1

(Event duration was 1.18 seconds long and AVC boosted voltage for full sag duration.)

AVC Input

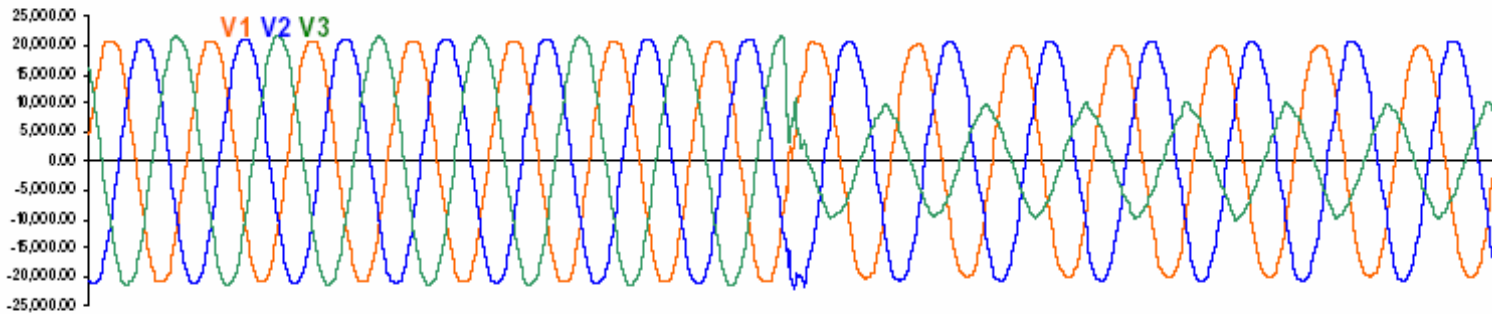

L-N Volt
V1=87%
V2=92%
V3=34%

AVC Output

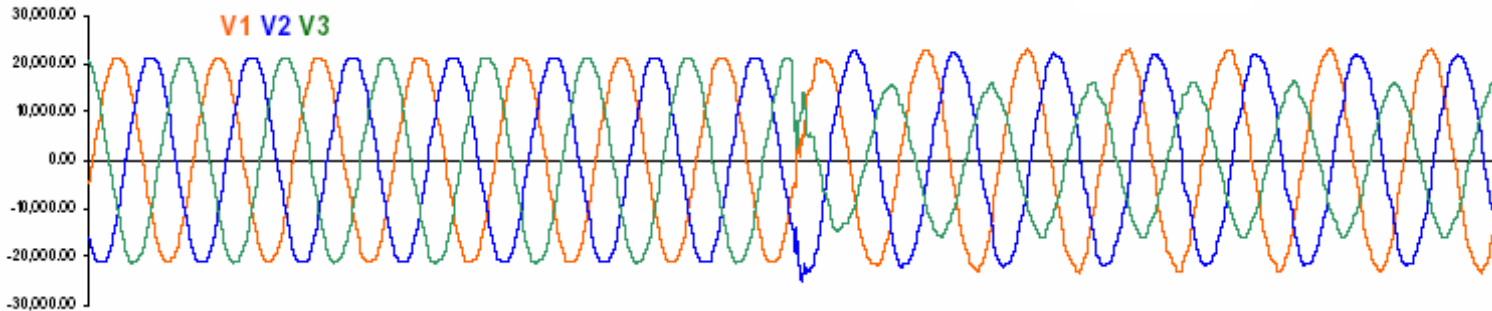

L-N Volt
V1=100%
V2=100%
V3=80%

L-L Volt
V1=100%
V2=90%
V3=90%

Field Measurements – Case 1

AVC Input

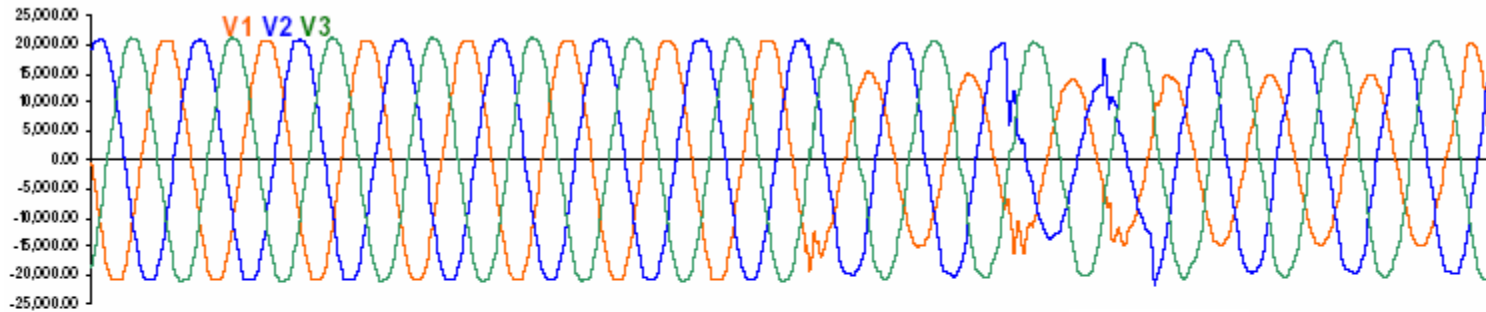

L-N Volt
V1=62%
V2=64%
V3=96%

AVC Output

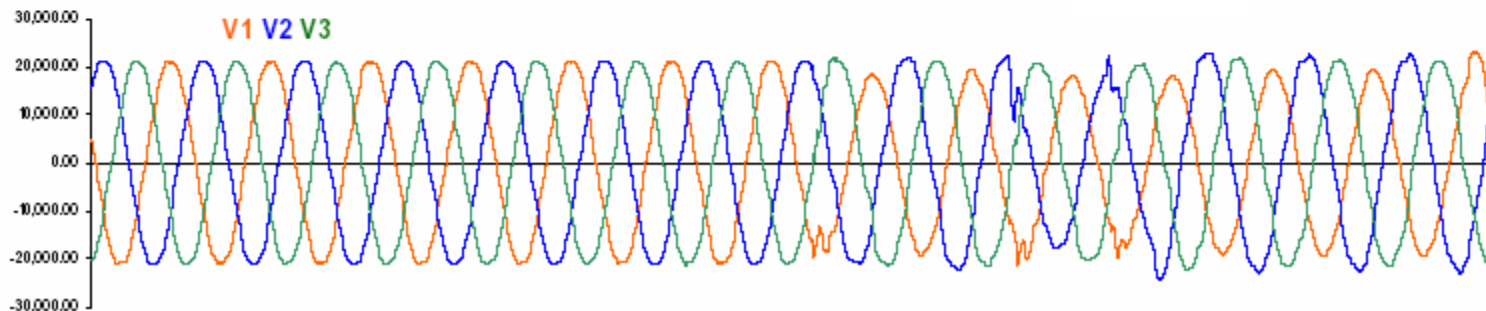

L-N Volt
V1=87%
V2=98%
V3=92%

L-L Volt
V1=90%
V2=91%
V3=91%

Field Measurements – Case 1

(Sag lasted 1 second)

AVC Input

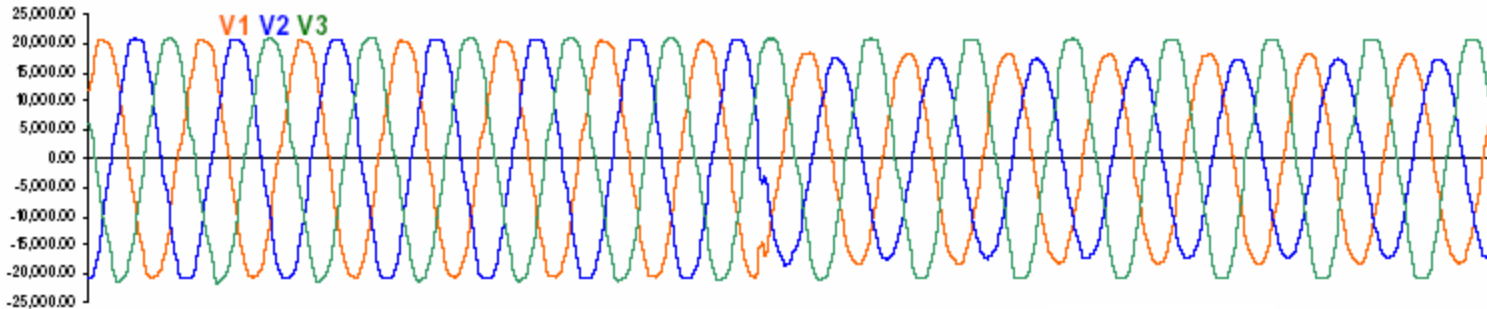

L-N Volt
V1=78%
V2=78%
V3=92%

AVC Output

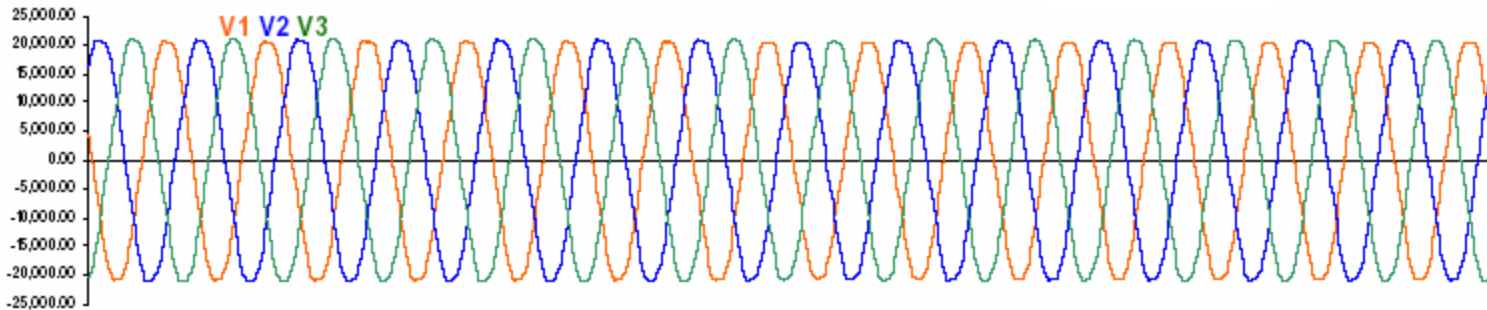

L-N Volt
V1=100%
V2=100%
V3=100%

Case 1 - Installation



High Voltage compartment (26kV)



Injection Transformer



Case 2 – Polyethylene Plant

- **115kV Utility supply**
- **8 -10 process upsets per year, most caused by lightning and birds**
- **Plant restart and recoveries in some cases took several days**
- **Lost production and damage to equipment were they the largest cause of loss**

Solution - Polyethylene

- **Customer originally requested 60MVA AVC protection but this was not cost effective**
- **Protected Extruders, Cutters and agitators only**
- **5 AVCs each 2MVA at 480V installed -2007**
- **To date averted 5 potential shutdowns**
- **Customer reported full project payback in first 4 events (Less than 6 months)**

Case 3 - Solar Cell Manufacturer

- **34.5kV Utility Supply**
- **Customer reported on average 18 process upsets per year prior to installation of AVC**
- **Estimated Cost per event \$125-250K**

Solution – Solar Cell Manufacturer

- **Installed 1600 KVA, 30% correction AVC, in 2002 (Indoor Unit)**
- **24 events recorded in first year of operation, AVC functioned as designed and protected the connected equipment**
- **The Customer, subsequently, installed 3 more units**
- **Currently, 10 more units are on order each at 1.5MVA for installation in December, 2008**

Case 3 - Solar Cell Manufacturer

1600 kVA, 2000 Amp, 480V AVC rated for 30% correction

Dimensions: 128" x 48" x 85"H



Case 4 - High Speed Printer

- **Incoming supply at 26.4 kV**
- **Densely treed plus high lightning area**
- **On average, process failed more than 40 times per year**
- **Failure resulted in Late delivery of product to customer**
- **Printer Maintenance costs over \$100K/year**

Solution – High Speed Printer

- **Installed 3000 kVA, 30% AVC – 2005**
- **Corrected all voltage sag events that occurred in 30 Months of operation**
- **Printing Press Maintenance costs virtually eliminated following installation of AVC**
- **Customer reported project payback was achieved in 4 months**

Case 4 - High Speed Printer

3000 kVA, 480V AVC rated for 30%



**The World's largest power protected site - 190MVA
semiconductor application, 4 Million ft² Semiconductor
FAB, 130 x 1,500kVA AVCs, All units 208V**



Container Crane, 100% Regenerating Application 18 - 400kVA AVCs



Conclusions

- **Voltage Sag is Considered the Most Costly Power Quality Problem**
- **Mitigation Equipment Including AVC are Readily Available to Address the Voltage Sag on a Plant Wide or at Process specific level**
- **Conduct Power Quality Study to Determine any Existing System Abnormalities and when Installing new Equipment**
- **On-Line Monitoring Equipment are readily Available for Power Quality Measurements**

www.ieee.ca

ANY QUESTIONS, PLEASE !

Thank You

